



**CADET FIELD MANUAL
FOR THE
NAVY JUNIOR RESERVE OFFICERS
TRAINING CORPS
(NJROTC)**



CADET FIELD MANUAL

(12th Edition)

NAVEDTRA 37116-L

April 2024

0509-LP-002-6028



0509LP1158559

THIS PAGE LEFT INTENTIONALLY BLANK

CADET FIELD MANUAL TABLE OF CONTENTS

PREFACE	2
ACKNOWLEDGMENTS	3
THE CORE VALUES OF THE NAVY JUNIOR RESERVE OFFICERS TRAINING CORPS	1
CHAPTER 1: NJROTC UNIFORM REGULATIONS	2
A. THE UNIFORM	2
B. GENERAL	2
1. Smartness.....	2
2. Care of the Uniform	3
3. Uniform of the Day	3
C. THE WEARING OF THE UNIFORM	4
D. PERSONAL APPEARANCE AND GROOMING	5
1. Men’s Grooming Standards.....	5
2. Women’s Grooming Standards	6
E. UNIFORM COMPOSITION	9
1. General	9
2. Female Uniforms.....	11
3. Uniform Appearance, Cleanliness and Maintenance	12
4. Male Uniforms	14
5. Female Uniforms.....	24
6. Unisex Uniforms	33
F. HOW TO TIE THE MALE NECKTIE	34
G. NJROTC UNIFORM INSIGNIA AND DEVICES	36
1. The NJROTC Patch.....	36
2. Service Stars	36
3. Collar Devices	36
4. Hat/Cap Devices	37
5. Aiguillettes (Cords).....	37
6. Awards and Decorations	38
CHAPTER 2: MILITARY CUSTOMS, COURTESIES, ETIQUETTE, AND CEREMONIES	49
A. GENERAL	49
B. THE AMERICAN FLAG AND FLAG ETIQUETTE	50
C. FLAG COURTESIES	52

D. PLEDGE OF ALLEGIANCE	54
E. CEREMONIES.....	56
1. Elements of Ceremonies.....	56
2. Flag Ceremonies.....	56
3. Types of Ceremonies	56
F. REVIEWS	57
1. Composition of a Review.....	57
2. Preparations of the Review Area.....	57
3. Cadet Formation	58
4. Troop Formations	59
5. Presentation and Honors	60
6. Company In Line.....	60
7. Inspection	60
8. March in Review.....	61
9. Presentation of Decorations.....	61
G. STREET PARADES.....	64
CHAPTER 3: PERSONNEL INSPECTION	72
H. GENERAL	72
I. FORMING FOR INSPECTION	72
J. INSPECTING OFFICER’S TOUR.....	73
K. INSPECTION GUIDELINES	74
L. SAMPLE INSPECTION SCORE SHEET	76

PREFACE

The purpose of the "NJROTC CADET FIELD MANUAL" is to provide information on military drill ceremonies and uniform regulations. You may come to think of this Field Manual as the "guide" for the military aspects of your association with the NJROTC program. This manual is based on current Naval Service Training Command (NSTC) Instructions. In the event there is a difference, the most current NSTC Manual 5761.1 publication will apply.

The uniform regulations chapter of this manual is important. From this chapter you will learn the importance of attention to detail.

The reasons why military drill specifically is important for you to learn during your time in the NJROTC are very basic. If you keep them in mind during your drill and parade activities, these reasons will become a part of you whether you are the leader or the follower. Here are the purposes of military drill:

To enable a leader to move his/her unit from one place to another in a standard and orderly manner.

To teach discipline by instilling habits of precision and automatic response to orders.

To increase the confidence of cadets through the exercise of command, and by giving proper commands, and by the control of drilling cadets.

To help cadets learn to safely and correctly handle drill rifles.

While enrolled in the NJROTC program, you will be instructed and drilled in all applicable safety precautions and procedures. Your naval science instructor will maintain situational awareness and ensure that safe practices are complied with at all times during your training in NJROTC activities. An immediate "**Training Time Out**" (TTO), shall be called whenever you or your naval science instructor experience apprehension concerning training safety. The TTO is explained in the Drill Manual.

Notes:

The terms "naval science instructor" and "NSI" in this manual include both the Senior Naval Science Instructor and the Naval Science Instructor.

To facilitate understanding of the significant changes to this manual from previous editions, they are marked with an asterisk (*) prior to the article in which they appear. Those articles should be carefully read and understood. However, other minor changes have been made which serve to clarify various articles. They are not so marked; therefore, the program office recommends a careful reading of the entire manual. Questions concerning these and other changes should be referred to the Area Manager via the Curriculum Advisory Board Representative.

ACKNOWLEDGMENTS

We wish to express appreciation to several individuals who contributed to the successful completion of this manual. Thanks are due to the members of the NJROTC Curriculum Advisory Board, a select group of naval science instructors who represent the 23 NJROTC geographical areas in the United States.

THE CORE VALUES OF THE NAVY JUNIOR RESERVE OFFICERS TRAINING CORPS

As a member of the NJROTC, we are dedicated to the Navy Core Values of HONOR, COURAGE, and COMMITMENT to build the foundation of trust and leadership upon which our NJROTC unit is based. These are the principles which will give us strength and guide us in our daily activities; we will be faithful to these Core Values as our abiding duty and privilege.

I AM ACCOUNTABLE FOR MY PERSONAL BEHAVIOR. I WILL BE MINDFUL OF THE PRIVILEGE I HAVE TO SERVE MY FELLOW NJROTC CADETS AND CLASSMATES.

HONOR; "I will bear true faith and allegiance...." Accordingly, we will: Conduct ourselves in the highest ethical manner in all relationships with peers, superiors, and subordinates; Be honest and truthful in our dealings with each other and with those outside of NJROTC; Be willing to make honest recommendations and to accept those of junior personnel; Encourage new ideas and deliver the bad news, even when it is unpopular; Abide by an uncompromising code of integrity, taking responsibility for our actions and keeping our word; Fulfill or exceed our legal and ethical responsibilities in our public and personal lives twenty-four hours a day. Illegal or improper behavior or even the appearance of such behavior will not be tolerated. We are accountable for our school, classroom, and personal behavior.

COURAGE IS THE VALUE THAT GIVES ME THE MORAL AND MENTAL STRENGTH TO DO WHAT IS RIGHT, WITH CONFIDENCE AND RESOLUTION, EVEN IN THE FACE OF TEMPTATION OR PERSONAL ADVERSITY.

COURAGE; "I will support and defend...." Accordingly, we will: Have the courage to meet the demands of our NJROTC unit when it is demanding or otherwise difficult; Make decisions in the best interests of the NJROTC unit and the school, without regard to personal consequences; Meet these challenges while adhering to a high standard of personal conduct and decency; Be loyal to our NJROTC unit and our fellow cadets and classmates, ensuring the resources entrusted to us are used in an honest, careful, and efficient way.

THE DAY-TO-DAY DUTY OF CADET IN THE NJROTC PROGRAM IS TO JOIN TOGETHER AS A TEAM TO IMPROVE THE QUALITY OF OUR UNIT, OUR FELLOW CADETS AND CLASSMATES, AND OURSELVES.

COMMITMENT; "I will obey the orders...." Accordingly, we will: Demand respect up and down the chain of command; care for the safety, professional, personal, and spiritual well-being of our fellow cadets and classmates; Show respect toward all individuals without regard to race, religion, or gender; Treat each person with human dignity; Be committed to positive change and constant improvement; Exhibit the highest degree of moral character, technical excellence, quality, and competence in what we have been entrusted to do.

These are the CORE VALUES of the Navy and the Navy Junior Reserve Officers Training Corps.

CHAPTER 1: NJROTC UNIFORM REGULATIONS

A. THE UNIFORM

1. The Navy Junior Reserve Officers Training Corps is one of the uniformed Junior Reserve Officers Training Corps (JROTC) programs. The uniform is an important element in the morale, pride, discipline, and effectiveness of the NJROTC program in your school. It is important for NJROTC cadets to maintain a high standard of dress and personal appearance. The key elements are neatness, cleanliness, safety, and military image. The purpose of this section in the Cadet Field Manual is to acquaint you with the wearing of the Navy Junior Reserve Officer Training Corps uniform.
2. The military uniform is a symbol of the nation's defense forces. It projects an image of devotion to duty in the service of one's country. The word "uniform" comes from a combination of two Latin words, *unus* and *forma*, which means "one form." Thus, the word "uniform" suggests a distinctive mode of dress. In ancient times, military dress acquired a certain degree of sameness but in a much different design from the modern military uniforms. They were, nevertheless, military uniforms in the sense that all the soldiers looked alike. To this extent, we assign the origin of the military uniform to an early date in western civilization.
3. The uniform worn by the Navy Junior ROTC cadets is the same, with certain exceptions, as that worn by active-duty Navy personnel. Cadets do not wear commissioned officer rank insignia, combination cover bill, or sleeve braid. Uniform articles must not be worn with other civilian clothing nor should they be loaned to others who are not members of the Navy Junior ROTC program. You are obligated to wear the uniform properly and proudly, and in doing so, you uphold the dignity of the Navy, your NJROTC unit, fellow cadets, and yourself.

B. GENERAL

1. Smartness

Wearing the Navy uniform should be a matter of personal pride to all NJROTC cadets. Your dress and conduct shall be such as to reflect credit upon your NJROTC unit, your school, your community, the Navy, and your country. Caps shall be worn squarely on the head, with the bottom edge horizontal. Shoes shall be kept well shined and in good repair. No articles, such as cell phones, pencils, pens, watch chains, jewelry, combs, or similar items shall be worn exposed when in uniform.

2. Care of the Uniform

The maximum service life of the various uniform articles can only be attained with proper care and maintenance. No matter how well-fitting your uniform is when new, it will not continue to look its best or keep its shape unless it is carefully pressed and worn properly. By carrying large or heavy objects in the pockets, you can rapidly destroy the shape of the best uniform made. You should always hang the uniforms on a hanger when not in use. Many items must be dry cleaned instead of washed. Be careful not to damage clothing through improper care. Uniforms shall be kept clean, neat, and in good repair. Insignia and devices shall be bright and free from tarnish and corrosion.

3. Uniform of the Day

The uniform of the day is the uniform your naval science instructor (NSI) will direct you to wear on any given day. The uniform color, Navy blue, is actually black in appearance. The Service Dress Blue uniform (officers and chiefs) and the Navy Service Uniform (enlisted) is the uniform you may be directed to wear year-round in most climates. Sweaters (V- neck) and jackets may be authorized in cooler climates. In the warmer climates, you may be directed to wear the Service uniform year-round.

The only uniforms authorized for cadet wear are those described in this manual and available through the current issue of the NJROTC Supply Manual NAVEDTRA 3712.3B. The most updated uniform listing is in Citizenship Development Management Information System (CDMIS).

C. THE WEARING OF THE UNIFORM

1. The NJROTC uniform will be worn by all cadets at least one full school day each week and on other occasions as prescribed by your naval science instructor (drills, ceremonies, and parades). Certain modifications to NJROTC uniforms may be authorized for drill teams and performing units. Such items include leggings, ascots, berets, and guard helmets. **However, modifications to cadet uniforms must be approved by the Area Manager in advance.** When appropriate, reflective gear such as armbands, vests, and sashes is authorized. Wearing uniform articles of sister services with the NJROTC uniform are not authorized.
2. The alternate combination cover (ACC) (optional for officers and chiefs) or the garrison cap (enlisted) is a required part of your NJROTC uniform. When outdoors, you shall be covered at all times except when ordered to uncover, or during religious services which are not associated with a military ceremony. While the cap is not normally worn indoors, it is required while on official duty when wearing a guard belt and/or leggings.
3. Cadets are to be in a complete uniform and in compliance with the uniform standards described in this manual anytime they are in uniform. The wearing of partial or incomplete uniforms so that the uniform can be "preserved" for inspection is not permitted. **Cadets will meet uniform standards whether they are standing an NJROTC inspection or attending other school classes in uniform.**
4. Uniforms for special occasions such as a field day shall be prescribed by the naval science instructor. All cadets participating at field meets will either be in the complete NJROTC uniform prescribed for the meet or a complete athletic uniform.
5. Uniformed cadets may not participate during or in connection with political activities, private employment, or commercial interests that imply official sponsorship of the activity or interest or at any other occasion when the wearing of the uniform would discredit the NJROTC program or the Navy.
6. You may be required to wear a name tag at the discretion of your NSI. When worn, it shall be positioned on the right side of the uniform, aligned and positioned opposite the ribbons on the left side. The bottom of the name tag will be aligned with the bottom row of ribbons. Refer to the illustrations in this chapter.
7. For field activities during which a normal uniform might become soiled or dirty, such as orienteering or some service projects, the NJROTC supply system has cargo pants available for unit purchase and issue, which may be worn with a unit tee shirt.

D. PERSONAL APPEARANCE AND GROOMING

(see also: [https://www.mynavyhr.navy.mil/References/US- Navy-Uniforms/Uniform-Regulations/Chapter-2/2201-Personal-Appearance/#fig%202-2-1](https://www.mynavyhr.navy.mil/References/US-Navy-Uniforms/Uniform-Regulations/Chapter-2/2201-Personal-Appearance/#fig%202-2-1))

1. Men's Grooming Standards

<u>Hair:</u>	Keep hair neat, clean and well groomed (combed or brushed). Hairstyles and haircuts will present a balanced professional appearance. Hairstyles worn in uniform will not interfere with the wearing of all uniform covers or the proper wearing of safety equipment. Hair coloring is left to the discretion of the instructors. Note: Ethnic hairstyles are permitted, provided they are groomed to fit within the guidelines stated here. Bizarre hairstyles and faddish hair are not authorized.
<u>Sideburns:</u>	Neatly trimmed and tailored as described here. Shall not extend below a point level with the middle of the ear, as indicated by line A and shall be of even width (not tapered or flared). Shall end with a clean-shaven horizontal line.
<u>Mustaches:</u>	Neat and closely trimmed. No portion shall extend below the upper lip line. Shall not be below the horizontal line extending across the corners of the mouth. Shall not be more than ¼ inch beyond a vertical line drawn upward from the corners of the mouth. No other facial hair is permitted
<u>Fingernails:</u>	Will not extend past the fingertips.
<u>Earrings/Studs:</u>	Not authorized in the ear, nose, eyebrows, tongue, lips, or other areas of the face or body visible to the naval science instructor.
<u>Necklaces:</u>	Authorized, but shall not be visible.
<u>Rings:</u>	One per hand is authorized.
<u>Wristwatch/Bracelet:</u>	One of each is authorized but no ankle bracelets.
<u>Sunglasses:</u>	A conservative pair is permitted when authorized by the naval science instructor. Sunglasses are never authorized in military formations. Retainer straps are not authorized.

2. Women's Grooming Standards

Hair:

Hairstyles will not detract from a professional military appearance in uniform. Hairstyles and haircuts will present a balanced professional appearance. Appropriateness of a hairstyle will be evaluated by its appearance when headgear is worn. All headgear will fit snugly and comfortably around the largest part of the head without distortion or excessive gaps. Hairstyles will not interfere with the proper wearing of headgear, protective masks or equipment. All buns and ponytails will be positioned on the back of the head to ensure the proper wearing of all headgear.

Hair Length:

Hair length, when in uniform, may touch, but not fall below a horizontal line level with the lower edge of the back of the collar. Long hair, including braids, will be neatly fastened, pinned, or secured to the head. When bangs are worn, they will not extend below the eyebrows. Hair length will be sufficient to prevent the scalp from being readily visible (with the exception of documented medical conditions).

Hair Bulk:

Hair bulk (minus the bun) as measured from the scalp will not exceed 2 inches. The bulk of the bun will not exceed 3 inches when measured from the scalp and the diameter of the bun will not exceed or extend beyond the width of the back of the head. Loose ends must be tucked in and secured.

Hair Color:

Hair color will be left to the discretion of the instructors.

Ponytails:

1. A ponytail is a hairstyle in which the hair on the head is pulled away from the face, gathered and secured at the back of the head with an approved accessory. Hair extending beyond the securing accessory may be braided or allowed to extend naturally. The wear of a single braid, French braid, or a single ponytail in Service, Working, and PT uniforms is authorized. The following criteria pertain to the wearing of ponytail hairstyles while wearing a U.S. Navy uniform.

Ponytail hairstyles will not interfere with the proper wearing of military headwear and equipment nor extend downward more than three inches below the lower edge of the collar

(shirt/blouse, jacket or coat) while sitting, standing or walking. Additionally, ponytails will not extend outward more than three inches behind the head as measured from the securing accessory, nor shall the width exceed the width of the back of the head or be visible from the front. In spaces or environments where there are operational hazards such as rotating gear, etc., the hair may not be worn below the bottom of the collar.

Hair Accessories:

When hair accessories are worn, they must be consistent with the hair color. A maximum of two small barrettes, similar to hair color, may be used to secure the hair to the head. Bun accessories (used to form the bun), are authorized if completely concealed. Additional hairpins, bobby pins, small rubber bands, or small thin fabric elastic bands may be used to hold hair in place, if necessary. The intent is for pinned-up hair to be styled in a manner that prevents loose ends from extending upward or outward from the head.

Hair Ornaments:

Must be consistent with the hair color. A maximum of two small barrettes, similar to hair color, may be used to secure the hair to the head. Bun accessories (used to form the bun), are authorized if completely concealed. Headbands, “scrunchies,” combs, claws, and butterfly clips are examples of accessories that are not authorized. Conspicuous rubber bands, combs, and pins are not authorized.

Cosmetics:

Applied in good taste and colors that blend with natural skin tone. Exaggerated or faddish cosmetics are inappropriate. Lipstick should be conservative.

Fingernails:

Fingernails shall not exceed ¼ inch measured from the fingertip. They shall be kept clean. Nail polish may be worn, but colors shall be conservative and complement the skin tone.

Earrings/Studs:

One per ear, centered on the earlobe. Must be a small gold or silver ball (post or one per ear, centered on the earlobe. Studs are not authorized in the nose, eyebrows, tongue, lips, or other areas of the face or body visible to the naval science instructor.

Necklaces: Authorized but shall not be visible.

Rings: One per hand is authorized, plus the engagement ring or the wedding ring.

Wristwatch/Bracelet: One of each is authorized but no ankle bracelets.

Sunglasses: A conservative pair is permitted when authorized by the naval science instructor. Sunglasses are never authorized in military formations. Retainer straps are not authorized.

NOTE: Personal appearance such as the wearing of lip rings, tongue and nose studs, belly rings, and other types of bizarre body jewelry, for both males and females when out of uniform, will be determined by the local school or NJROTC student dress codes.

E. UNIFORM COMPOSITION

1. General

Listed here are the uniforms and items you will wear with the uniform. These uniforms shall be worn when prescribed by your instructor.

- a. All personnel, officer and enlisted, are authorized to wear the **Navy Service Uniform**.
- b. Officers and chiefs are authorized to wear the Service Dress Blue Uniform; and Service Khaki (only when pre-approved by the Area Manager, and then only in conjunction with on-campus events such as weekly uniform days, or evening assemblies). Service Khaki is not authorized for wear at Area Manager or Off Site Inspections, formal Unit Changes of Command, or any event where there are likely to be multiple JROTC units attending.
- c. All personnel of the Color Guard, when performing, are authorized to wear the Service Dress Blue uniform.
- d. The ACC with white cover is authorized for wear by officers and chiefs only and can be worn with Service Dress Blue uniforms. The ACC with khaki cover is authorized for wear by officers and chiefs only and can be worn with Naval Service Uniforms. The white ACC may be worn by the color guard when performing. The chin strap (gold for officers, black for chiefs) is adjusted to fit snugly against the cap. Chin strap buttons will be gold. Wear the black chin strap with the grommet to the left. The cap should be worn squarely on the head with the bottom edge parallel to and 1-½ inches above the eyebrows. Caps with “scrambled eggs” are NOT authorized for wear by cadets at any time.
- e. The blue garrison cap shall be worn by all cadets with the Navy Service uniform.
- f. Wear the cap squarely on the head with the fore and aft crease centered vertically between the eyebrows and the lowest point approximately 1 inch above the eyebrows. When indoors, the garrison cap may be stowed by placing it under the belt on the right or left side of the uniform.



Figure 1. An image of the garrison cap.

- g. Cadets are not authorized to wear Service Khaki without prior approval of the Area Manager.
 - i. A one-piece, black, hand-tied necktie will be worn with the Male Service Dress Blue uniform. The tie will be knotted with a four-in-hand, half Windsor, or Windsor knot. Wear the top of the knot parallel to and slightly above the top of the shirt collar closure, hiding the shirt button. The bottom of the tie hangs within 1 inch above the top of the belt buckle. The tie does not cover the belt buckle.
- h. An optional tie tack/clasp can be worn with the uniform tie. This tack/clasp must be plain gold and aligned between the 3rd and 4th button from the neck.
- i. Shoes shall be Navy-style plain black leather, low quarter, lace-style shoes with no stitching, decoration, or seam across the toe. Shoes shall be laced inside out through all eyelets and shall be well-shined. Poromeric (e.g., Corfam) shoes are optional but might not be authorized to be worn when standing some inspections or competing in some drill meets.
- j. Uniform socks shall be black plain knit or rib knit socks.
- k. Plain white crew neck or V-neck tee shirts shall be worn with all uniforms at the direction of the Senior Naval Science Instructor (SNSI).
- l. Black gloves are authorized for outdoor wear as an optional item; however, they must be purchased by the wearer. Reimbursement is not authorized.
- m. Raincoats, peacoats (reefers) or all-weather coats may be prescribed for wear in certain areas of the country. Gold buttons are worn on all peacoats. Neither the NJROTC patch nor rank insignia are worn on the raincoat, peacoat, or all- weather coat.
- n. Watch caps are authorized for wear with working uniforms as an option.
- o. The black relaxed fit jacket may be worn with all uniforms except the Service Dress Blue uniform. Rank insignia is not allowed on the relaxed fit jacket. The NJROTC patch is worn on the left shoulder with the top edge 1 inch below the shoulder seam. The female overblouse shall not be visible below the bottom edge of the relaxed fit jacket. When worn, all jackets and coats must be zipped at least 3/4 of the way up.
- p. Ball caps are authorized with the Navy Service uniforms as an optional item, as shown here. They can be of unit design but in good taste. School colors are authorized.



Figure 2. An image of the NJROTC ball cap.

- q. The black V-neck Navy pullover (SWO) sweater is authorized for daily wear with the Navy Service Uniforms. Additionally, it may be worn in lieu of the Service Dress Blue blouse in the classroom but not as an inspection uniform. Either a unit plastic or a Velcro backed, black leather name tag (2 inches x 4 inches) is required. Rank insignia are not authorized. The shirt collar is worn inside the sweater when a tie is worn and outside the sweater when no tie is worn.



Figure 3. An example of a Velcro backed nametag.

At the discretion of the Area Manager, units may authorize the blue cargo pant for activities off campus in situations when the activities justify the need for a “working uniform” and in which wear of the service uniform would not be appropriate due to the possibility of the uniform becoming soiled or damaged. When so authorized, the pant may be worn with an NJROTC or unit ball cap and the Navy PT shirt or a unit polo or tee shirt. Footwear will be at the discretion of the SNSI, depending upon the activity involved, and the pants will not be worn with the cuffs bloused. Cadets will wear the male, black uniform belt with brass buckle. At the discretion of the Area Manager, the Navy black Rigger’s belt may be substituted for the dress uniform belt.

2. Female Uniforms

- a. The female cadet uniforms and items are only slightly different from the male uniforms.
- b. Maternity uniforms are authorized for wear; however, they cannot be purchased with government funds. These items must be paid for by the cadet.
- c. A black necktab with an adjustable neckband will be worn when required. The necktab's outer edges should be parallel to the outer edges of the collar. An equal amount of the necktab should show on each side of the collar.
- d. Hosiery shall be made of nylon and be similar in color



Figure 4. An image of two NJROTC cadets.

to the tone of your skin. When slacks are worn, black plain knit or rib knit socks will be worn in lieu of hosiery.

- e. Shoes shall be Navy-style plain black laced leather oxfords. Shoes shall be laced inside out through all eyelets and shall be well-shined. Plain black dress pumps are authorized for wear as an optional item with dress uniforms for female cadets enrolled only in Naval Science Two and above. The plain black dress pumps shall be made of smooth calf leather, with closed heels and toes. Heels shall be no higher than 2-5/8 inches nor less than 5/8 inch measured from the forward edge and no wider than 1-3/4 inches at the base. The sole shall be no thicker than 1/4 inch. Wedge heels are not authorized. Poromeric (e.g., Corfam) shoes are optional but might not be authorized to be worn when standing some inspections or competing in some drill meets.
- f. Skirts shall be hemmed to within 1½ inches above or below the crease in the back of the knee.
- g. The pleat in the back of the skirt shall be hemmed for a 6-inch opening.
- h. Plain white crew neck or V-neck tee shirts shall be worn with all uniforms at the direction of the SNSI.
- i. The handbag, if carried, must be a plain black leather or synthetic purse.

3. Uniform Appearance, Cleanliness and Maintenance

- a. Uniforms shall be kept clean, neat, and in good repair.
- b. Shirts should be pressed with a properly placed NJROTC patch. No buttons with Irish pennants nor holes in the collar from misplaced insignia are allowed.
- c. Trousers and skirts should be pressed, well-fitting, proper length with no lint or stains visible.
- d. Shoes should be highly polished in their entirety, not just the toe area.
- e. Hats should be clean and well-fitting. Combination covers and chin straps should be tight. Eagles on the hat buttons should be in the upright position.
- f. Insignia and devices shall be clean and bright and free from tarnish and corrosion. Metal polish such as Brasso© will remove the plating and should not be used for cleaning purposes.
- g. Brass buckles and belt tips should be shined with quartermaster removed. Polish residue in the slide area should be removed.
- h. Gold buttons that become tarnished can be cleaned with vinegar, followed by a thorough washing in clean water.
- i. The manufacturer's cleaning instructions should be followed for the cleaning and laundering of all uniforms:

- j. Service Dress Blue - Coat, trousers, skirt, tie/necktab, and slacks are dry cleaned only. White shirt is laundered.
- k. Service Khaki – Shirt, trousers, and slacks may be laundered or dry cleaned. If laundered, they must be pressed.
- l. ACC cover is laundered; garrison caps are dry cleaned only.
- m. Black relaxed fit jacket and raincoat are dry cleaned only.
- n. Care must be exercised when using bleach in the laundering of white articles. Chlorine bleach on white polyester fabric turns it yellow.
- o. Military creases on shirts for Navy Service Uniforms are an individual option. Uniform Composition.

4. Male Uniforms

i. NAVY SERVICE

<u>Basic Uniform Items:</u>	<u>Color:</u>
<u>Awards/Ribbons/Medals/Cords</u>	
Belt, brass tip	Black
Buckle	Brass
Cap, garrison.	Blue
Shirt, s/sleeve	Khaki
Shoes.	Black
Socks.	Black
Undershirt	White (V-neck or crewneck)
<u>Outerwear:</u>	
All-weather coat	
V-neck sweater	
Relaxed Fit Jacket	Black
Parka/fleece	

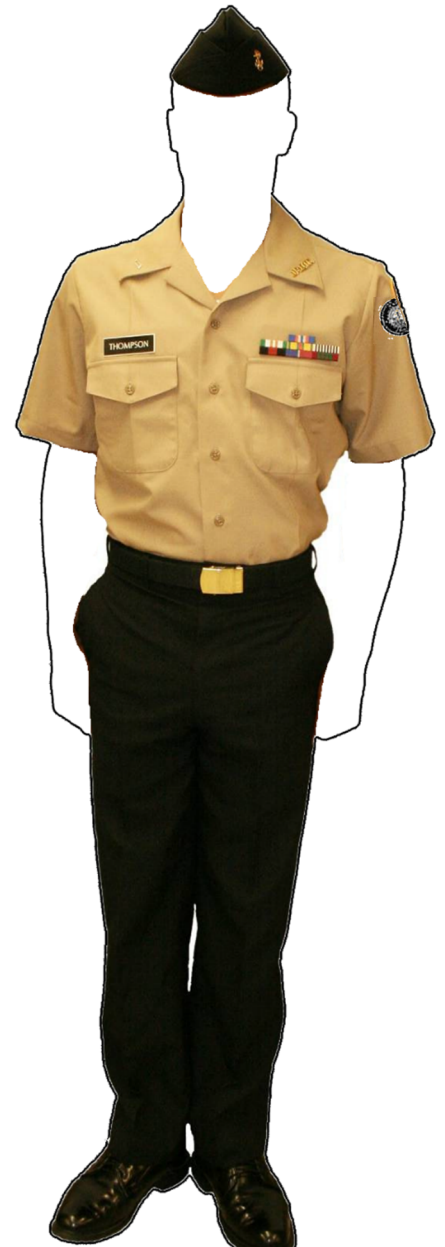


Figure 5. Male Navy Service Uniform.

MALE'S SHORT SLEEVE SERVICE SHIRT (Khaki)

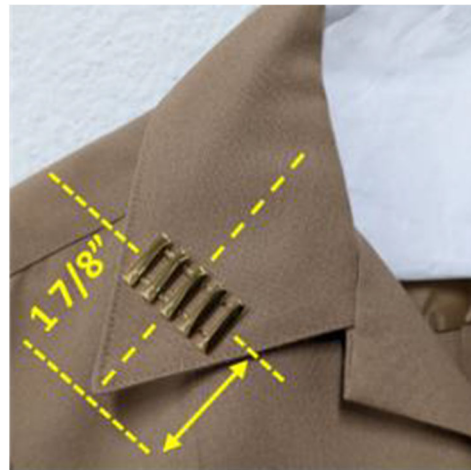
The vertical axis of the rank/rate insignia and the vertical axis of the JROTC bar insignia are positioned along an imaginary line bisecting the angle of the collar point. The center of each insignia is 1-7/8 inch from the collar point.

Service stars are worn 1/4 inch above the top row of ribbons. One star is centered, and multiple stars that are not joined as a single device are 1/4 inch apart from each other, centered on the ribbons. Multiple stars joined as a single device shall be centered on the ribbons.

Ribbons and name tag are worn parallel to the top of the shirt pocket, 1/4 inch above and centered on the pocket button hole. Medals are worn 1/4 inch below the top of the pocket, similarly centered.

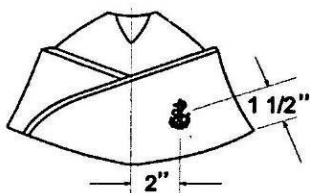


SA/Seaman

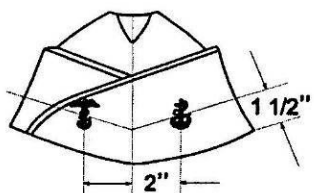


Officer

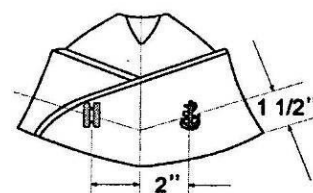
UNISEX BLUE GARRISON CAP



SA/Seaman/P



CPO



Officer

The blue garrison cap is worn with the Service uniform.

The small fouled anchor is worn on the garrison cap. The anchor is worn on the wearer's left side of the cap. The center of the anchor is bisected by a vertical line 2 inches from the fore crease of the garrison cap and a horizontal line 1-½ inches from the bottom edge of the cap.

Only officers and chiefs wear the rank/rate insignia on the garrison cap. It is worn on the wearer's right side. The center of the rank/rate insignia is bisected by a vertical line 2 inches from the fore crease of the garrison cap and a horizontal line 1-½ inches from the bottom edge of the cap.

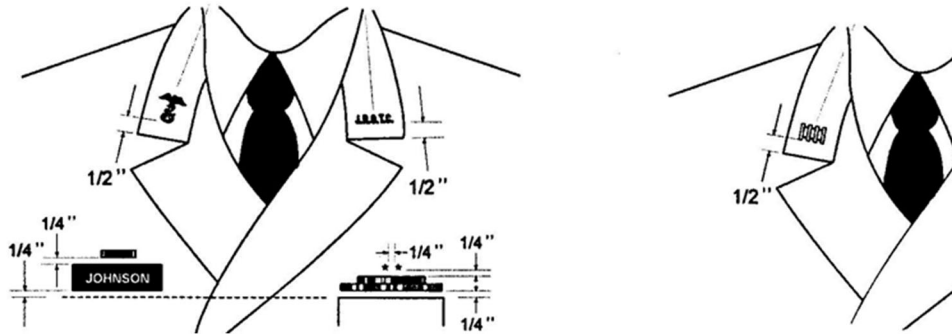
ii. **SERVICE DRESS BLUE**

<u>Basic Uniform Items:</u>	<u>Color</u>
Awards/Medals/Cords	
Belt, brass tip	Black
Buckle	Brass
Cap, combination cover	White
Coat	Blue
Necktie	Black
Shirt, long-sleeve	White
Socks	Black
Shoes	Black
Slacks	Blue
Undershirt	White (V- or crewneck)
<u>Outerwear:</u>	
Peacoat	
All-weather	
Relaxed Fit Jacket	
<u>Optional Items:</u>	
Cap, garrison	Blue



Figure 6. Male Service Dress Blue Uniform.

MALE'S SERVICE DRESS BLUE COAT (Officers/CPOs)



Chief Petty Officer

Officer

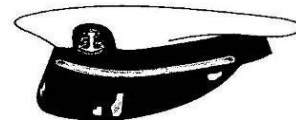
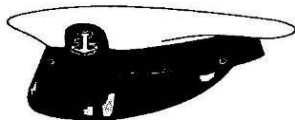
The JROTC bar and rank/rate insignias for the male's Service Dress Blue coat are positioned on the collar $\frac{1}{2}$ inch above the notch in the lapel and parallel to the deck. The vertical axis of each insignia is centered between the outer edges of the coat collar. The JROTC bar insignia is worn on the wearer's left side; the rank/rate insignia is worn on the wearer's right side.

Name tag and ribbons are parallel to the deck, not to the coat pocket, $\frac{1}{4}$ inch above and centered on the coat pocket. Medals are worn $\frac{1}{4}$ inch below the top of the pocket, similarly centered.

Service stars are worn $\frac{1}{4}$ inch above the top row of ribbons. One star is centered, and multiple stars that are not joined as a single device are $\frac{1}{4}$ inch apart from each other, centered on the ribbons. Multiple stars joined as a single device shall be centered on the ribbons.

ACC (Officers/CPOs)

Chief Petty Officer Officer



The large fouled anchor is worn on the ACC. Cadet chief petty officers wear a black chin strap on the cap; cadet officers wear a gold chin strap.

UNISEX GARRISON CAP

(Officers/CPOs) (Optional)



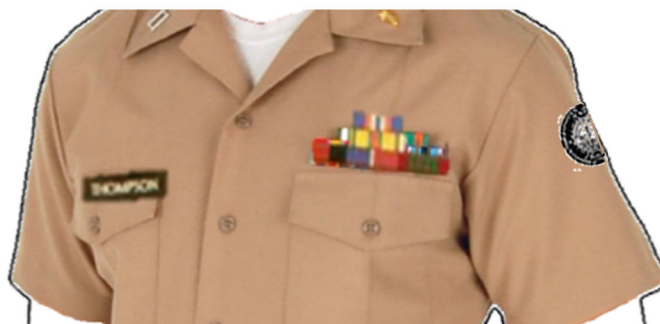
The small fouled anchor and rank/rate insignias are worn on the garrison cap for officers and chiefs. The anchor is worn on the wearer's left side of the cap; the rank/rate insignia is worn on the wearer's right side. The center of the anchor insignia and the center of the rank/rate insignia is bisected by a vertical line 2 inches from the fore crease of the garrison cap and a horizontal line 1 ½ inches from the bottom edge of the cap.

iii. SERVICE KHAKI

<u>Basic Uniform Items:</u>	<u>Color</u>
Awards/Medals/Cords	
Belt, brass tip	Khaki
Buckle	Brass
Cap, garrison	Khaki
Shirt, short-sleeve	Khaki
Socks	Black
Shoes	Black
Slacks	Khaki (poly-wool, not cotton)
Undershirt	White (V- or crewneck)
<u>Outerwear:</u>	
All-weather coat	
V-neck sweater	
Relaxed fit jacket	Black
Raincoat	
<u>Optional Items:</u>	
Cap, combination	Khaki

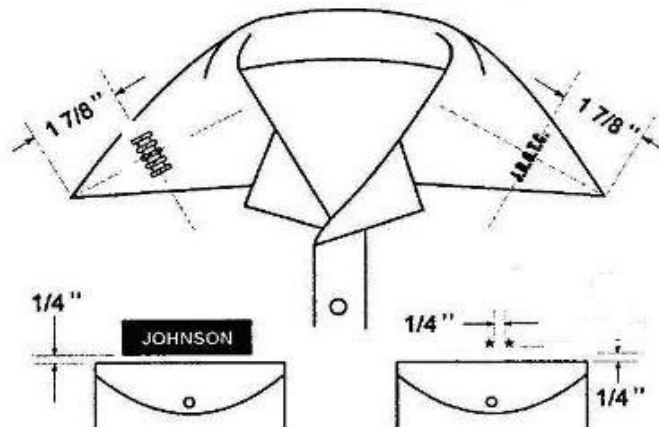


Figure 7. Male Service Khaki Uniform.



NOTE: Cadets are not authorized to wear Service Khaki without prior approval of the Area Manager. When approved by the Area Manager, Service Khaki is only authorized for wear by cadet officers and chief petty officers, and only in conjunction with on-campus events such as weekly uniform days or evening assemblies. It is not authorized for wear at Area Manager or Off-Site Inspections, formal Unit Changes of Command, or any event where there are likely to be multiple JROTC units attending.

MALE'S SERVICE KHAKI SHIRT

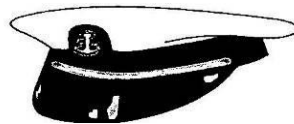
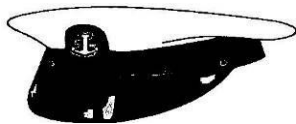


The vertical axis of the rank/rate insignia and the vertical axis of the JROTC bar insignia is positioned along an imaginary line which bisects the angle of the collar point. The center of the rank/rate insignia and the center of the JROTC bar insignia is positioned 1-7/8 inch from the collar point.

*Ribbons and name tag are worn parallel to the top of the shirt pocket, 1/4 inch above and centered on the pocket button hole. Medals are worn 1/4 inch below the top of the pocket, similarly centered.

Service stars are worn 1/4 inch above the left pocket or top of all ribbons. One star is centered, and multiple stars that are not joined as a single device are 1/4 inch apart from each other, centered on the pocket. Multiple stars joined as a single device shall be centered on the pocket.

ACC (Officers/CPOs)



The large fouled anchor is worn on the ACC. Cadet chief petty officers wear a black chin strap on the cap; cadet officers wear a gold chin strap.

MALE'S KHAKI GARRISON CAP

(Officers/CPOs) (Optional)



The small fouled anchor and rank insignia are worn on the garrison cap for officers and chiefs. The anchor is worn on the wearer's left side of the cap; the rank/rate insignia is worn on the wearer's right side. The center of the anchor insignia and the center of the rank/rate insignia is bisected by a vertical line 2 inches from the fore crease of the garrison cap and a horizontal line 1½ inches from the bottom edge of the cap.

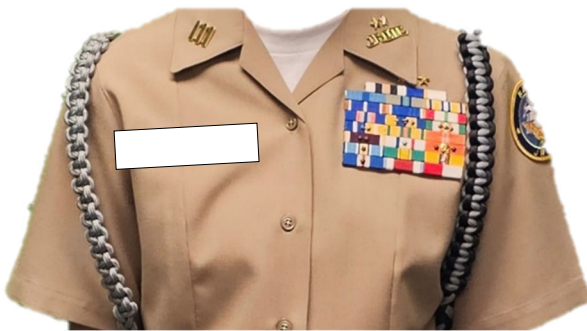
5. Female Uniforms

i. FEMALE NAVY SERVICE

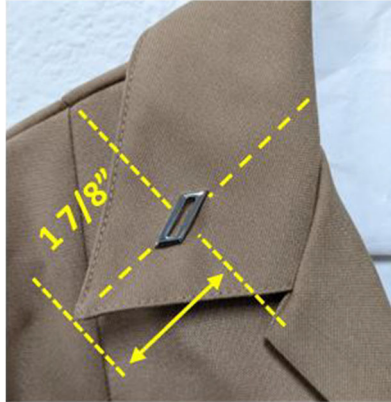
<u>Basic Uniform Items:</u>	<u>Color</u>
Awards/Medals/Cords	
Cap, garrison	Blue
Shirt, short-sleeve (unbelted)	Khaki
Shoes, Oxford	Black
Slacks	Blue
Socks	Black
<u>Outerwear:</u>	
All-weather coat	
V-neck sweater	
Relaxed fit jacket	Black
Raincoat	
<u>Optional Items:</u>	
Handbag	Black
Shoes, pumps	Black
Skirt	Black
Hosiery, tone	Flesh
Undershirt	White (V-neck or crewneck)



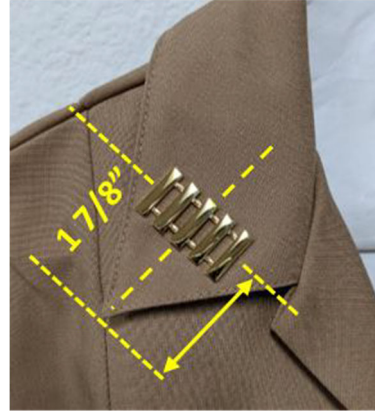
Figure 8. Female Navy Service Uniform



FEMALE'S SHORT SLEEVE SERVICE SHIRT (Khaki)



SA/Seaman



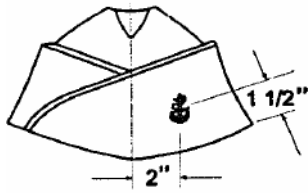
Officer

The vertical axis of the rank/rate insignia and the vertical axis of the JROTC bar insignia are positioned along an imaginary line bisecting the angle of the collar point. The center of each insignia is 1-7/8 inch from the collar point.

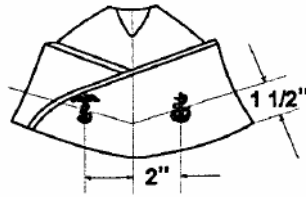
Service stars are worn 1/4 inch above the top row of ribbons. One star is centered, and multiple stars that are not joined as a single device are 1/4 inch apart from each other, centered on the ribbons. Multiple stars joined as a single device shall be centered on the ribbons.

*Placement of the bottom of the ribbons shall be approximately 6-1/4 inches down from the intersection of the front seam and shoulder seam and centered over the front seam. Name tags shall be placed in the same manner on the right side of the overblouse. Medals shall be worn 1/4 inch below the bottom row of ribbons.

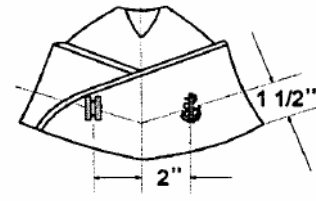
UNISEX BLUE GARRISON CAP



SA/Seaman/PO



CPO



Officer

The blue garrison cap is worn with the Service uniform.

The small fouled anchor is worn on the garrison cap. The anchor is worn on the wearer's left side of the cap. The center of the anchor is bisected by a vertical line 2 inches from the fore crease of the garrison cap and a horizontal line 1-½ inches from the bottom edge of the cap.

Only officers and chiefs wear the rank/rate insignia on the garrison cap. It is worn on the wearer's right side. The center of the rank/rate insignia is bisected by a vertical line 2 inches from the fore crease of the garrison cap and a horizontal line 1-½ inches from the bottom edge of the cap.

ii. **FEMALE SERVICE DRESS BLUE**

<u>Basic Uniform Items:</u>	<u>Color</u>
Awards/Medals/Cords	
Cap, combination	White
Coat	Blue
Necktab	Black
Shirt	White
Shoes, Oxford	Black
Slacks	Blue
Socks	Black
<u>Outerwear:</u>	
Peacoat	
All-weather coat	
Raincoat	
<u>Optional Items:</u>	
Cap, garrison	Blue
Cap, bucket	White
Skirt	Blue
Handbag	Black
Shoes, pumps	Black
Hosiery, tone	Flesh
Undershirt	White (V-neck or crewneck)

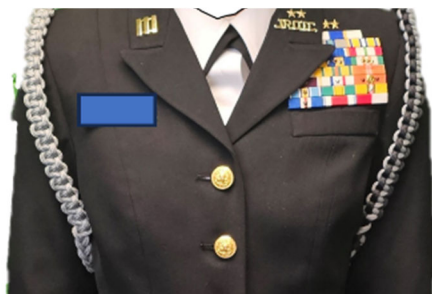
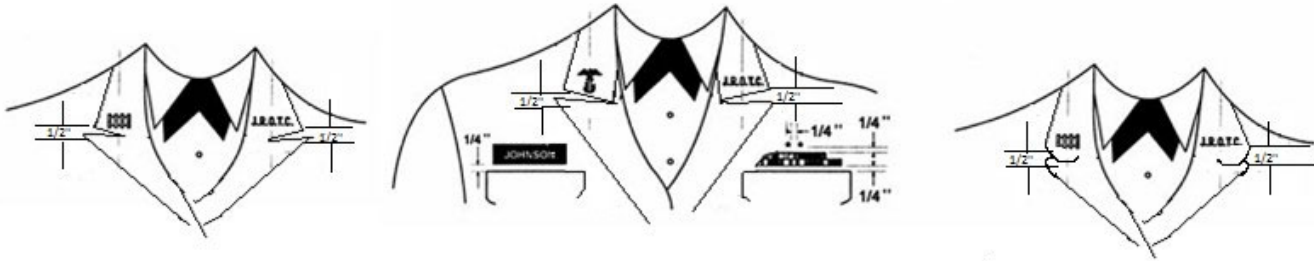


Figure 9. Female Service Dress Blue Uniform.

FEMALE'S SERVICE DRESS BLUE COAT

(Officers/CPOs)



Collar insignia should be positioned $\frac{1}{2}$ inch above the notch in the lapel and parallel to the deck. The fabric on the Service Dress Blue (SDB) coat, slacks, and skirt must match.

NOTE: Some units may have the older version of the Female SDB blouse which has a rounded collar. The JROTC bar and rank/rate insignias for this coat are positioned on the rounded end of the coat collar. The vertical axis of each insignia is centered between the outer rounded edges of the collar. The insignia are fixed in an upright position with the center of the insignias 1 inch from the semicircular bottom edge of the collar. In both cases, the JROTC bar insignia is worn on the wearer's left side; the rank/rate insignia is worn on the wearer's right side.

Name tag and ribbons are parallel to the top of the coat pocket, $\frac{1}{4}$ inch above and centered on the coat pocket.

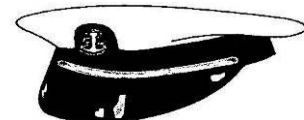
Service stars are worn $\frac{1}{4}$ inch above the top row of ribbons. One star is centered, and multiple stars that are not joined as a single device are $\frac{1}{4}$ inch apart from each other, centered on the ribbons. Multiple stars joined as a single device shall be centered on the ribbons.

*ACC (Officers/CPOs)

Chief Petty Officers



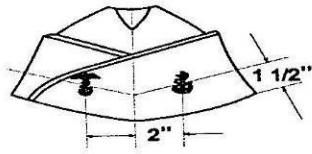
Officers



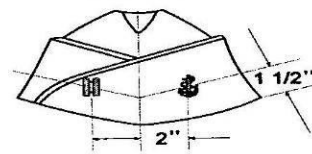
The large fouled anchor is worn on the ACC. Cadet chief petty officers wear a black chin strap on the cap; cadet officers wear a gold chin strap.

UNISEX GARRISON CAP (Optional)

Chief Petty Officer



Officer



The small fouled anchor and rank/rate insignias are worn on the garrison cap for officers and chiefs. The anchor is worn on the wearer's left side of the cap; the rank/rate insignia is worn on the wearer's right side. The center of the anchor insignia and the center of the rank/rate insignia is bisected by a vertical line 2 inches from the fore crease of the garrison cap and a horizontal line 1-½ inches from the bottom edge of the cap.

iii. **FEMALE SERVICE KHAKI**

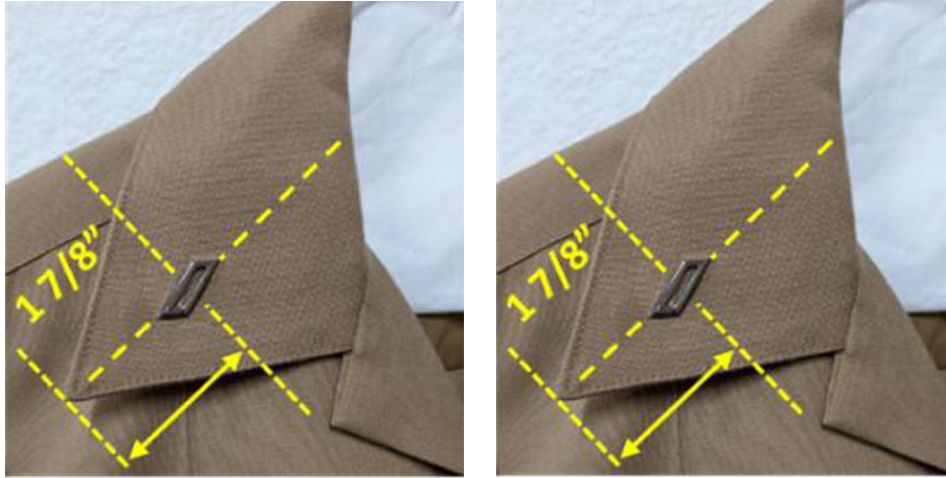
<u>Basic Uniform Items:</u>	<u>Color</u>
Awards/Medals/Cords	
Belt, brass tip	Khaki
Buckle	Brass
Cap, garrison	Khaki
Shirt	Khaki
Slacks	Khaki, poly-wool (NOT cotton)
Socks	Black
<u>Outerwear:</u>	
All-weather coat	
V-neck sweater	
Relaxed fit jacket	Black
Raincoat	
<u>Optional Items:</u>	
Handbag	Black
Shoes, pumps	Black
Skirt	Black
Hosiery, tone	Flesh
Undershirt	White (V-neck or crewneck)



*Figure 10. Female Service Khaki Uniform
(Officer/CPO Only)*

NOTE: Cadets are not authorized to wear Service Khaki without prior approval of the Area Manager. When approved by the Area Manager, Service Khaki is only authorized for wear by cadet officers and chief petty officers, and only in conjunction with on- campus events such as weekly uniform days, or evening assemblies. It is not authorized for wear at Area Manager or Off-Site Inspections, formal Unit Changes of Command, or any event where there are likely to be multiple JROTC units attending.

FEMALE'S SERVICE KHAKI SHIRT



The vertical axis of the rank/rate insignia and the vertical axis of the JROTC bar insignia is positioned along an imaginary line which bisects the angle of the collar point. The center of the rank/rate insignia and the center of the JROTC bar insignia is positioned 1-7/8 inch from the collar point.

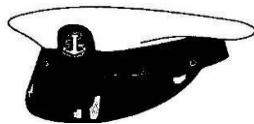
*Placement of the bottom of the ribbons shall be approximately 6-1/4 inches down from the intersection of the front seam and shoulder seam and centered over the front seam. Name tags shall be placed in the same manner on the right side of the overblouse. Medals shall be worn 1/4 inch below the bottom row of ribbons.

Service stars are worn 1/4 inch above the top row of ribbons. One star is centered, and multiple stars that are not joined as a single device are 1/4 inch apart from each other, centered on the ribbons. Multiple stars joined as a single device shall be centered on the ribbons.

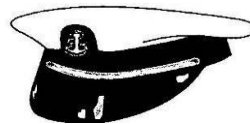
ACC (Officers/CPOs

)

Chief Petty Officers



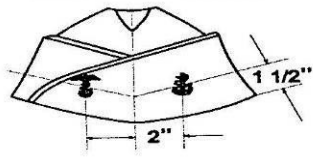
Officers



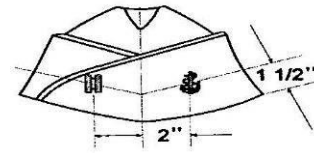
The large fouled anchor is worn on the ACC. Cadet chief petty officers wear a black chin strap on the cap; cadet officers wear a gold chin strap.

UNISEX GARRISON CAP

Chief Petty Officer



Officer



The small fouled anchor and rank insignia are worn on the garrison cap for officers and chiefs. The anchor is worn on the wearer's left side of the cap; the rank insignia is worn on the wearer's right side. The center of the anchor and rank insignia is bisected by a vertical line 2 inches from the fore crease of the garrison cap and a horizontal line 1 1/2 inches from the bottom edge of the cap.

6. Unisex Uniforms

i. NAVY WORKING UNIFORM (NWUs)

<u>Basic Uniform Items:</u>	<u>Color</u>
Cap	NJROTC
Blouse	NWU (Type III)
Undershirt	NWU (Type III)
Cadet Nametag and Patch	
Rank/Insignia	
Blousing Strap (around the boots)	Around
Socks	Black
Riggers Belt	Black
Trousers	NWU (Type III)
Boot Socks	Black
Boots	Black (male and female versions available)

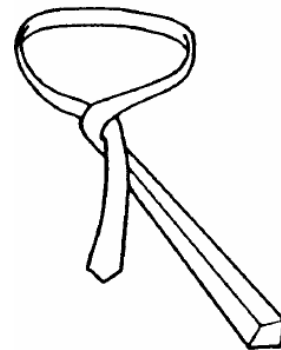
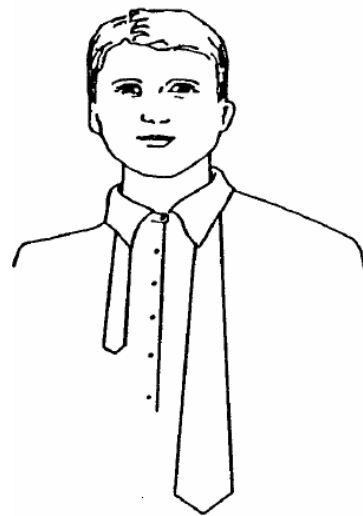


Figure 11. Navy Working Uniform (NWU).

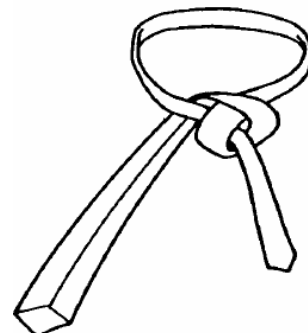
F. HOW TO TIE THE MALE NECKTIE

1. **Description:** Made of authorized fabric measuring no more than 3-¼ inches wide. Must be hand-tied.
2. **Correct Wear:** Wear tie knotted with a half Windsor, a Windsor, or a four-in-hand knot. Wear the top of the knot parallel to and slightly above the top of the shirt collar closure, hiding the top button. The bottom of the tie hangs within 1 inch of the top of the belt buckle. The tie does not cover the belt buckle.
3. **Directions:** The following diagrams on how to tie your tie with a half Windsor knot are shown while looking in a mirror.

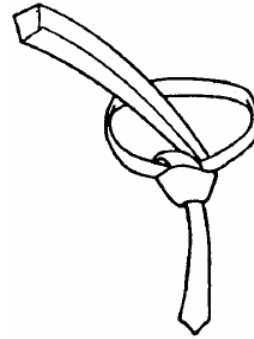
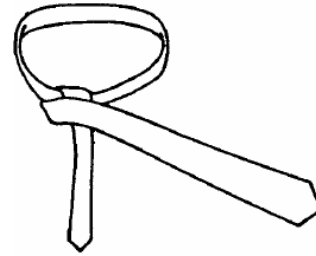
- (1) Place the wide end of your tie on the right side of your chest so it extends about 12 inches below the narrow end of the tie.



- (2) Cross the wide end of the tie over the narrow end and then back under.



- (3) Bring the wide end of the tie up and over the neck loop, then turn the wide end down under and through the neck loop.



- (4) Take the wide end of the tie and pass it in front of the narrow end from left to right.

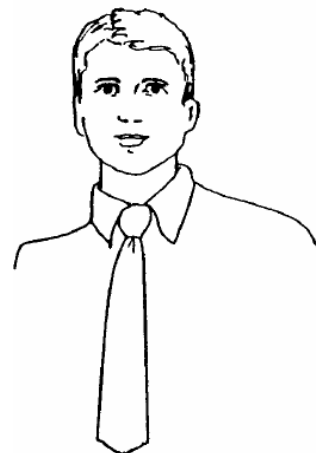


- (5) Pass the wide end of the tie up under and through the neck loop.



- (6) Bring the wide end of the tie down through the front of the knot.

- (7) Finish the tie by forming a dimple at the base of the knot, then tighten.



- (8) Slide up snug to the collar and center tie.

G. NJROTC UNIFORM INSIGNIA AND DEVICES

1. The NJROTC Patch

- i. The NJROTC patch depicts a ship, an anchor, and an eagle.
- ii. The NJROTC patch is worn on the left sleeve of the short sleeve khaki shirt, the Service Dress Blue coat, and the black relaxed fit jacket. It will be centered midway between the front and the rear of the shirt sleeve or coat sleeve, with the top edge 1 inch below the shoulder seam.



Figure 12. The NJROTC Patch.

- iii. The NJROTC patch is not worn on the raincoat, peacoat (reefer), all-weather coat, parka, or the long sleeve white shirt if worn with the Service Dress Blue uniform.

2. Service Stars

- i. The service stars indicate the course/year groups within the NJROTC program.
- ii. Note: For those NJROTC units under the 4X4 block schedule, course is synonymous with year for those NJROTC units under the A/B block schedule or the conventional schedule.
- iii. This insignia is used to designate number of courses/years satisfactorily completed in the program. The device is a five-pointed gold star (metal device) which is 3/8 inch diagonally across in size.
- iv. These stars shall be centered 1/4 inch above the left breast pocket or the ribbons, two points down. If more than one is awarded, they are spaced 1/4 inch apart. They shall be worn 1/4 inch above the ribbons on dress uniforms or 1/4 inch above Drone Wings if earned.

3. Collar Devices

All cadets will wear the JROTC device on the left shirt collar or the Service Dress Blue coat collar as shown in the uniform illustrations on pages FM-15 thru FM-30. Rank/rate devices will be worn on the right collar of the shirt and coat collar as shown in the uniform illustrations. The JROTC device or the rank and rate devices are not authorized for wear on the collars of the black relaxed fit jacket, the all-weather coat, the raincoat, or the peacoat.

4. Hat/Cap Devices

- i. ACC. The fouled anchor will be worn on the headband of the cap. The headband shall be arranged to eliminate the space below the seam of the white cover and its vertical band (known as a “smile”). The black and gold chin straps will be worn attached to the outside of the headband with gold cap buttons. Wear the black chin strap with the grommet to your left. The grommet looks like a small button that attaches to the top strap, allowing the strap to slide and change size. The gold chin strap does not have a grommet.



Figure 13. The Alternate Combination Cap (ACC).

- ii. Garrison Cap (Blue and Khaki). A fouled anchor will be worn by all cadets on the left side of the garrison cap. Cadet officers and chiefs will wear their rank/rate insignia on the right side of the garrison cap. Refer to the uniform illustrations beginning for correct positioning.

5. Aiguillettes (Cords)

- i. Aiguillettes may be awarded as earned for various academic and military achievements; they may be worn only on the Service Dress Blue and Service uniforms. Aiguillettes awarded by the naval science instructor for such things as color guard, drill team, academic team, etc., will be worn only on the left shoulder. Only the Leadership Academy aiguillette will be worn on the right shoulder. **NO MORE THAN ONE AIGUILLETTE MAY BE WORN ON EACH SHOULDER.**
- ii. Aiguillettes will be attached to the appropriate shoulder by a gold coat button on the Service Dress Blue uniform or a miniature anchor (garrison cap) on the Service uniforms. The button or anchor shall be placed so that the entire aiguillette hangs on the shoulder parallel to the seam of the coat or shirt. Aiguillettes are not authorized for wear on the raincoat, peacoat, all-weather coat, parka, or relaxed fit jacket.

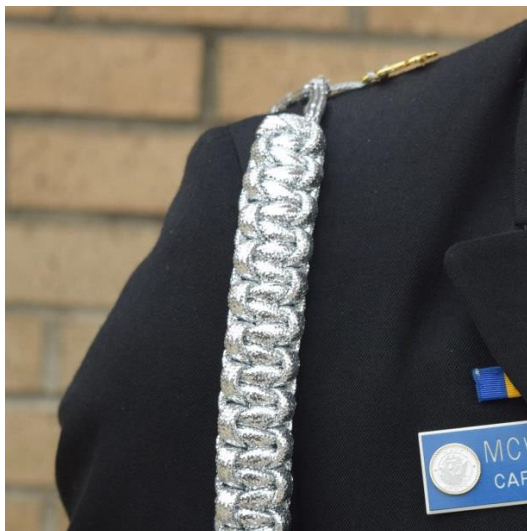


Figure 14. Cord.

6. Awards and Decorations

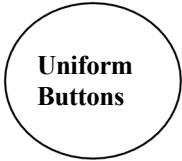
- a. **Wearing Ribbon Awards.** The NJROTC ribbons are worn only on the Service Dress Blue and the Navy Service uniforms. When more than three ribbons are earned, wear them in horizontal rows of three each. If ribbons are not in multiple of threes, the top row contains the lesser number, and the center of this row sits over the center of the row below. Wear ribbons without spaces between ribbons or rows of ribbons. The NJROTC ribbons will be worn with the lower edge of the bottom row centered $\frac{1}{4}$ inch above the left breast pocket of the shirt or coat. An adjustment may be necessary to make the ribbons parallel to the deck on the Service Dress Blue coat. To prevent the lapels on the SDB coat from covering ribbons, they may be aligned so the ribbon border to the wearer's left is aligned with the left side of the pocket. Rows of ribbons where more than 50 percent of the ribbon is covered by the SDB coat lapel may contain two ribbons each and be aligned with the left border.



- b. **Precedence or Order of Seniority.** NJROTC ribbons will be worn in the order of precedence as outlined in the Cadet Reference Manual. The most senior ribbon will be worn in the top row and inboard when more than one ribbon is worn on a row. All earned NJROTC ribbons must be worn at the same time; however, only one of each ribbon design may be worn with devices/subsequent awards attached to that one ribbon. Other awards and ribbons presented to you by organizations other than the NJROTC program (i.e., other service Junior ROTC programs, Retired Officers Association,

American Veterans, Order of Daedalians, American Legion, marksmanship, etc.) will be worn after (subordinate to) the NJROTC ribbons in the order determined by your SNSI.

- c. **NJROTC Medals.** Medals earned are worn only on uniforms where other awards and decorations are authorized. They will be positioned $\frac{1}{4}$ inch below the top of the pocket on the wearer's left breast. Medals will be centered immediately below the bottom row of ribbons, arranging in seniority order inboard to outboard, in the following order: (1) NJROTC academic competition, (2) NJROTC marksmanship competition, and (3) all others as prescribed by the SNSI. No more than three medals may be worn in each row side-by-side, or five medals in each row when overlapping, in addition to its corresponding ribbon, if any. When wearing multiple rows of medals, subsequent rows will be placed immediately below the previous row so that only the medallion of each medal is visible.
- d. **Honor Roll.** Awarded to any cadet who attains school honor roll status. The award is denoted by wearing a service star above the J-bar on the collar of any uniform. The star will be worn $\frac{1}{4}$ inch above and centered on the "O" of the JROTC device. Two service stars may be worn to indicate the cadet is on the principal's honor roll, should the school distinguish between honor roll and principal's honor roll status. (Normally, it is awarded to a student who has achieved a 4.0 (unweighted) or straight "A" grade average for a marking period). The award is only worn during such time as the cadet is on the current honor roll. If a cadet is no longer listed when a new honor roll is published, the award shall be removed.
- e. **NJROTC Ribbon Awards.** For awarding of ribbons, order of precedence and ribbon devices for subsequent awards refer to the Cadet Reference Manual.
- f. **Drone Wings.** When earned by passing the Federal Aviation Administration Part 107 Unmanned Aerial Vehicle certification test, the approved Drone Wings are to be worn centered and $\frac{1}{4}$ inch above the highest row of ribbons and $\frac{1}{4}$ inch below the service stars.
 - i. **Mounting Ribbons.** All earned ribbons are to be mounted on ribbon bars. Mounting bars are made to hold different numbers of ribbons. They present a neater appearance and help you align your ribbons on your shirt or coat. Arrange ribbons in order of precedence in rows from top down, inboard to outboard, within rows as shown in the example.



	4 – Honor Cadet	
7 - Aptitude	10 – Naval Sci 2	11 – Naval Sci 1
18 - Academic	19 – Drill Team	26 – Sea Cruise

Note: Refer to the Cadet Reference Manual for the requirements to be awarded NJROTC ribbons and their proper order of precedence.

Note: Four NJROTC ribbons can be worn incorrectly (upside down) with the colors reversed in order from the wearer's right to left. These are: Distinguished Cadet, Physical Fitness, Unit Service, and Color Guard. In all four cases, the ribbon should be mounted on the ribbon bar with the blue end of the ribbon to the wearer's right.



				bl	y	wh								
bl	y	bl	y	b	w	b	y	w	y	wh	b	wh	r	wh

Distinguished Cadet

Physical Fitness

Unit Service

Color Guard

Note: When the Physical Fitness, Unit Service, or Color Guard ribbon is moved to the wearer's right side, as in the case of a commanding officer or team captain, the ribbon is not turned upside down to have the dark color inboard. The ribbon is worn as shown with the blue portion to the wearer's right.

g. Wear of Active Duty Ribbons and Badges.

- i. On the rare occasion that a cadet earns an active duty award for service such as pre-graduation completion of boot camp, that award's ribbon may be worn on the uniform "above" (higher in priority than) NJROTC ribbons. However, the wear of the associated medal or its miniature equivalent is NOT authorized, since active duty regulations call for the wearing of medals only with full dress (Mess Dress for miniature medals).
- ii. As stated in previous sections, THE UNIFORM in this manual, the wear of

unearned active duty insignia and awards by a cadet is strictly prohibited. This prohibition includes but is not limited to commissioned officer rank insignia, combination cover bill (“scrambled eggs”), and/or sleeve braid, commissioning knots on swords, and all warfare or other qualification badges and breast insignia, especially command pins, command master chief or career counselor badges, and other active duty badges which have specific requirements for qualification. To wear these badges and breast insignia as a cadet would be disrespectful to the efforts, experience, and training that an active duty member or veteran had to undergo to achieve that qualification.

STUDY GUIDE QUESTIONS
CHAPTER 1: NJROTC UNIFORM REGULATIONS

1. What four elements are important when wearing the uniform?
2. Where does the word "uniform" come from? What does it mean?
3. NJROTC cadets and active duty Navy personnel wear the same uniform with certain exceptions. What are they?
4. How should caps be worn?
5. How should the uniform be kept?
6. What is the uniform of the day?
7. When may one uncover outdoors?
8. When must cadets comply with uniform requirements?
9. Who prescribes what uniform shall be worn for special occasions?
10. Can cadets, in uniform, participate in political activities?
11. The bulk of a man's hair may not exceed how many inches?
12. Men's sideburns may not extend below _____?
13. How should mustaches be kept?
14. What are the grooming standards for men regarding earrings and studs?
15. Are sunglasses authorized in military formations?

16. May the female hair extend to the collar?
17. How should females' cosmetics be worn?
18. What kind of nail polish is authorized?
19. What kinds of earrings/studs are authorized?
20. When can enlisted cadets wear the Service Dress Blue uniform?
21. Under what circumstances will a cadet be authorized to wear the khaki uniform?
22. How are the uniform shoes required to be laced?
23. What are the rules regarding hosiery for female cadets?
24. On Service Khaki uniforms shirts, where are the collar devices worn?
25. Who is authorized to wear rank/rate insignias on the garrison cap?
26. On which side is the fouled anchor worn on the garrison cap?
27. On all uniforms, where is the name tag worn?
28. What is the maximum number of service stars that can be worn on the NJROTC uniform?
29. Where are service stars worn on Navy Service and Service Dress Blue uniform?
30. What color is the chin strap on the combination cover for cadet chief petty officers?
31. What types of knots are authorized for the male tie?

32. Which aiguillette is only authorized to be worn on the right shoulder?
33. On which uniforms are aiguillettes not authorized?
34. Where are medals worn on the NJROTC uniform?
35. What is the highest award that can be earned by a NJROTC cadet? Who is authorized to award it?
36. What is the maximum number of awards of any ribbon that can be earned by a NJROTC cadet? How is this distinguished on the ribbon?
37. Which ribbon(s) are authorized to be worn on the wearer's right side?
38. What are the four ribbons which can be worn "incorrectly" (i.e., upside down)?
39. What is the general rule of thumb for wearing ribbons?

CRITICAL THINKING QUESTIONS

Official clothing for sailors was a hit-or-miss affair until 1747, when King George

II of England ordered uniforms to be worn by all navy personnel. He did this as a means of boosting sailors' morale and improving their appearance. The first uniforms for the U.S. Navy, authorized on September 5, 1776, specified outfits for officers. These included a blue coat, blue breeches, and a red waistcoat with narrow lace.

Enlisted uniforms were first authorized in September 1817. The winter uniform included a black hat, blue jacket, blue trousers, and a red vest, all with yellow buttons. Rating badges for enlisted men were first worn in 1885. It appears that as the United States Navy was being established, a standard designed naval uniform was not an issue. Do you think the standardization of a naval uniform, including placement of rank and various insignia, is important? What criteria would you use to assess a standard design for the naval uniform? Is there any inconvenience that might arise from not being able to distinguish the commissioned officers from the enlisted personnel?

EXTENSION ACTIVITY

1. The vintage clothing field, with its emphasis on the clothes of women and children, tends to reflect youthful and feminine lives. But when finding men's clothes, we think about adult male lives, and we shouldn't forget an overwhelming force in those lives: the military. A lot of the world's clothing is military, and uniforms directly affect the history of clothing.
2. The question of whether uniforms belong to the world of military collectables or vintage clothing is important. Uniform study has to be part of costume study, and it's radically different from other costume fields because of the wealth of documentation available and the emphasis on the original wearer.
3. Research various military museums to learn about vintage military uniforms and how the uniform designs and materials have affected the design, function, and practicality of civilian clothing that we wear today.
4. Why spend your time flipping through the large Cadet Field Manual? Using the Cadet Field Manual, Chapter 1 NJROTC Uniform Regulations as a guide, design and make a small (5 inch x 6 inch) NJROTC uniform guide flip chart. This would be a quick reference guide complete with an index, illustrations, detailed instructions, and a measuring template for placement of all NJROTC insignia on the uniforms.

INTERDISCIPLINARY CONNECTION

1. Global Studies: Research the foreign origins of military uniforms and the historical background that formed the basis of the U.S. Navy enlisted and officer uniforms. Create a poster of the early British Royal Navy uniforms and the early U.S. Navy uniforms, including the initial rank and rank insignia.

ACADEMIC CONTENT STANDARDS

Language Arts 1: Uses the general skills and strategies of the writing process. Benchmarks: Evaluates own and others' writings; uses strategies to address writing to different audiences; uses strategies to adapt writing for different purposes; writes expository compositions; writes fictional, biographical, autobiographical, and observational narrative compositions; writes persuasive compositions that address problems/solutions or causes/effects; writes reflective compositions; writes in response to literature.

Language Arts Standard 7: Demonstrates competence in the general skills and strategies for reading a variety of informational texts. Benchmarks: Applies reading skills and strategies to a variety of informational texts; knows the defining characteristics of a variety of informational texts; determines the effectiveness of techniques used to convey viewpoint; uses discussions with peers as a way of understanding information.

Technology Standard 3: Understands the relationships among science, technology, society, and the individual. Benchmark: Knows that alternatives, risks, costs, and benefits must be considered when deciding on proposals to introduce new technologies or to curtail existing ones.

Historical Understanding Standard 2: Understands the historical perspective. Benchmarks: Understands that specific individuals and the values those individuals held had an impact on history; analyzes the influence specific ideas and beliefs had on a period of history; analyzes the effects that specific "chance events" had on history; analyzes the effects specific decisions had on history.

VOCABULARY WORDS

Uniform

From a combination of two Latin words, *unus* and *forma*, which means “one form.”

Uniform of the Day

The uniform of the day is the uniform your Senior Naval Science Instructor (SNSI) will direct you to wear on any given day.

Legging

A canvas cloth covering for the leg.

Ascot

A broad neck scarf that is looped under the chin.

Garrison Cap

A visorless folding cap worn as part of a military uniform.

SDB

Service Dress Blue

Service Stars

This insignia is used to designate the number of courses/years satisfactorily completed in the NJROTC program.

Precedence

Priority of importance

Quartermaster

A thin lacquer coating applied to brass devices, particularly belt buckles and tips, to protect the surface while in shipment and storage.

Gig Line

The alignment of the seams of the shirt and trouser fly with the edge of the belt buckle.

Smile

The white fabric of the combination cover which shows between the black band and the seam of the upper cover. When the cover is correctly rigged or set up, there should be no smile visible.

Brass on Brass

The alignment of the tip of the belt with the base of the belt buckle.

CHAPTER 2: MILITARY CUSTOMS, COURTESIES, ETIQUETTE, AND CEREMONIES

OBJECTIVES

1. Explain the types of military customs and courtesies, including their purposes and when courtesies are rendered.
2. Describe the flag of the United States as a standard of honor. Explain the procedures in pledging allegiance to the flag.
3. Describe the sequence of events in military ceremonies, reviews, and parades.

A. GENERAL

Military customs and courtesies are the traditional way by which nations and individuals pay respect to distinguished persons and foreign governments. Customs and courtesies are also used to show reverence for people and places of historical distinction, significance, and sanctity. The type of courtesy rendered depends upon who or what is being recognized. Courtesies are salutes to ships, to high-ranking individuals, and to nations. Courtesies are not rendered to nations or officials not recognized by the United States or to officials who request that they not be rendered.

Ceremonies are formal, traditional acts of respect and/or reverence performed on public occasions. Like customs and courtesies, military ceremonies are an integral part of military life. Ceremonial occasions range from morning and evening colors to the courtesies and ceremonies observed by ships when passing Washington's tomb at Mount Vernon, Virginia, or the USS ARIZONA Memorial in Pearl Harbor, Hawaii. There are numerous kinds and types of ceremonies, far too many to cover in this chapter. To learn more, your unit library should have the Naval Institute Press book: *Naval Ceremonies, Customs, and Traditions*.

B. THE AMERICAN FLAG AND FLAG ETIQUETTE

1. The flag of the United States of America is a vibrant symbol that calls to our spirit, reminding us of the greatness of our America. We cherish and uphold it because it is the standard of honor under which we live.
2. We view the flag with devotion, for it represents our national heritage of noble deeds, splendid accomplishments, and untold sacrifices that combined to establish the moral character of our national foundation. Our flag is a symbol that makes our past one with the present and makes the present a prophecy for tomorrow.
3. Our flag signifies a people dedicated to liberty, justice, and freedom for all.
4. Our flag is our companion around the world.
5. It summons confidence on sight. There is a magic in its folds that continually renews the hope that this nation, under God, will long be an example everywhere for all who love freedom with honor.
6. We give homage to the flag because it stands for the courageous, earnest, and unselfish experiences of people who have given us strength as a nation and pride as citizens.
7. We respect our flag because we have respect for our countrymen and because our love for country finds its center in our flag.
8. The customs and traditions that surround the display and use of our flag are guides to the means by which we, as proud and grateful citizens, may demonstrate the ultimate respect for the flag of our nation.
9. It is the universal custom to display the flag only from sunrise to sunset on buildings and on stationary flagstaffs in the open. However, when a patriotic effect is desired, the flag may be displayed 24 hours a day if properly illuminated during the hours of darkness.
10. The flag should not be displayed on days when the weather is inclement, except when an all-weather flag is displayed.
11. The flag should be displayed daily on or near the main administration building of every public institution and during school days in every schoolhouse.
12. The flag should be displayed on all days, especially on all national and state holidays, such as New Year's Day, Inauguration Day, President's Day, Washington's Birthday,



Easter Sunday, Armed Forces Day, Memorial Day (half-staff until noon), Flag Day, Independence Day, Labor Day, Columbus Day, Navy Day, Veteran's Day, Thanksgiving Day, Christmas Day, birthdays of states (date of admission), and such other important days as may be proclaimed by the President of the United States.

13. The flag should be displayed daily in or near every polling place on election days.
14. When the flag is in such condition that it is no longer a fitting emblem for display, it should be destroyed in a dignified way, preferably by burning.
15. The flag and the national anthem are symbols of all the people, their land, and their institutions. When we salute these symbols, we are saluting the nation. Military personnel follow specific procedures in showing their respect to the flag and the national anthem. Flags and national anthems of friendly foreign nations are shown the same respect as our own. In honoring and saluting our flag, we demonstrate respect for our nation, our fellow citizens, and the proud heritage we share.



C. FLAG COURTESIES

The following courtesies are rendered during the ceremony of hoisting or lowering the flag, during outdoor or indoor ceremonies, or when the flag is passing in a parade or in review:

When Outdoors in Uniform. When in uniform outdoors and the national anthem or "To the Colors" is played, stand at attention, face the flag (if the flag is not visible, face the music), and render the military salute. The salute begins on the first note of the music and is held until the last note.



When Outdoors in Civilian Clothes. When in civilian clothes and the national anthem or "To the Colors" is played, stand at attention and face the flag (if the flag is not visible, face the music). A male removes his hat, holds it in his right hand, and places his right hand over his heart. A female does the same, except the hat, if worn, is not removed.

To An Escorted Flag Outdoors. When attending any outdoor event in uniform and the U.S. flag is escorted past you, stand at attention, face the front, and render the appropriate salute. Render the salute six paces before the flag is even with you, and hold it until the flag has passed six paces beyond you. Miniature flags, such as those displayed at downtown parades, are not saluted.

On a Stationary Flagstaff. When in uniform, do not salute flags on stationary flagstaffs except during morning and evening colors ceremonies.

During Indoor Ceremonies. When ceremonies occur indoors and the national anthem or "To the Colors" is played, face the flag, take the position of attention, and place your hand over your heart. If the flag is not visible, take the position of attention and face the music or the front. When in uniform indoors, do not salute unless you are covered or under arms. No action is required while ceremonies are occurring outdoors and you are indoors. Also, there is no requirement for a person to stand or salute for ceremonies broadcast over radio or television.



Private Vehicle Passengers. On a military base at the first note of the national anthem, all vehicles must come to a complete stop. Occupants sit quietly until the last note of the music is played before resuming travel.

At Half-Staff. The flag is flown at half-staff to honor and pay respect to deceased persons of

national importance. The term “half-staff” means the position of the flag when it is half the distance between the top and the bottom of the staff.

D. PLEDGE OF ALLEGIANCE

The pledge of allegiance shall not be recited in military formations and ceremonies. At protocol functions or social and sporting events that include civilian participants, personnel in uniform should: (a) when outdoors, stand at attention, face the flag, remain silent, and render the hand salute; (b) when indoors, stand at attention and face the flag, but do not salute. Reciting the pledge of allegiance is optional for military personnel when indoors. All persons present in civilian clothes when outdoors should remove their hats, face the flag, stand at attention with their right hand over their heart, and recite the following:

"I pledge allegiance to the flag of the United States of America, and to the republic for which it stands, one nation under God, indivisible, with liberty and justice for all."

I:	You and me, an individual, a person
PLEDGE ALLEGIANCE TO THE FLAG:	Take a vow, an oath, a promise. Duty owed to your country, observance of obligation. A symbol of liberty and freedom that we as free men and women do so jealously cherish.
OF THE UNITED STATES:	Joined together, combined, and produced by two or more persons, a union our forefathers put together in 1776, to make us a united people free of a tyrant or an oppressor.
OF AMERICA:	A land blessed with brotherhood from sea to shining sea. A land full of natural resources, a land where anyone can do what he/she wants as long as it does not violate the rights of another.
AND TO THE REPUBLIC:	A state in which the supreme power rests in the body of citizens entitled to vote and is exercised by elected representatives.
FOR WHICH IT STANDS:	A flag known throughout the world as a symbol of freedom. A nation in which people can worship as they please, speak and not be afraid of being censored for what they say, or express an opinion in writing and not be afraid of being arrested for writing what they feel.
ONE NATION:	A body of people associated with a particular territory, who are conscious of their unity. One body of people speaking the same language, yet opening doors to those foreign to us and saying, "Welcome."
UNDER GOD:	Meaning we have been so blessed.

INDIVISIBLE:	Incapable of being divided. Even with our own internal problems, our people—when sensing someone trying to take away our freedom—will answer the call to put down an adversary. We will unite.
WITH LIBERTY:	Freedom from outside control. Freedom from captivity and freedom from dictatorship, with the right to choose our own government.
AND JUSTICE:	The quality of being just; equitable, fair treatment for all, regardless of social background or economic standing. The right to be heard, to see our accusers, to question why.
FOR ALL:	Not just a chosen few, but for everyone in the land.

E. CEREMONIES

1. Elements of Ceremonies

Ceremonies are formal events and typically require an understanding of such aspects as the organization, purpose, composition, and administration of the various parts of ceremonies.

2. Flag Ceremonies

Flag ceremonies occur during parades, during morning and evening colors, and prior to special events. Morning colors is the signal for the START of the official duty day. Retreat signals the END of the official duty day. Most flag ceremonies will be conducted with the national anthem. The bugle calls "To the Colors" (in the morning) and "Retreat" (in the evening) can be used when a band is not available or during bad weather. They are given the same respect as the national anthem. During these ceremonies, all military and civilian personnel render the proper courtesies.

3. Types of Ceremonies

- a. There are four types of ceremonies.
 - i. Reviews
 - ii. Decorations (awards)
 - iii. Parades
 1. Ceremonial
 2. Street
 - iv. Funerals and special ceremonies

b. Commander of Troops

The commander of the troops in a ceremony is the senior officer taking part in it. He is responsible for the organization, uniform, and equipment of the units participating in the ceremony, along with any other necessary administrative information.

c. Unit Commanders

During ceremonies, unit commanders give commands, units execute drill movements, and units employ formations described in this manual for the squad, platoon, and company. Formations for ceremonies may be modified by commanding officers when the nature of the grounds or exceptional circumstances require such changes.

d. The Place of Formation

The place of formation for participating in a ceremony is as directed by the commander of the unit.

F. REVIEWS

1. Composition of a Review

A review consists of four parts:

1. Formation of the unit
2. Presentations and honors
3. Inspection (or trooping the line)
4. March in review

2. Preparations of the Review Area

- i. The line on which the cadets are to form and along which they are to march is marked out by the host organization for the review. In the field, the post for the reviewing officer, opposite the center of the line of troops, is marked on each flank with a flag. The illustration (Field Marking in Preparation for a Review) shows the minimum markings for a review area. Additional flat markers may be used to designate the subordinate unit commander's posts, unit guide posts, and turning points for approaching the line of troops.

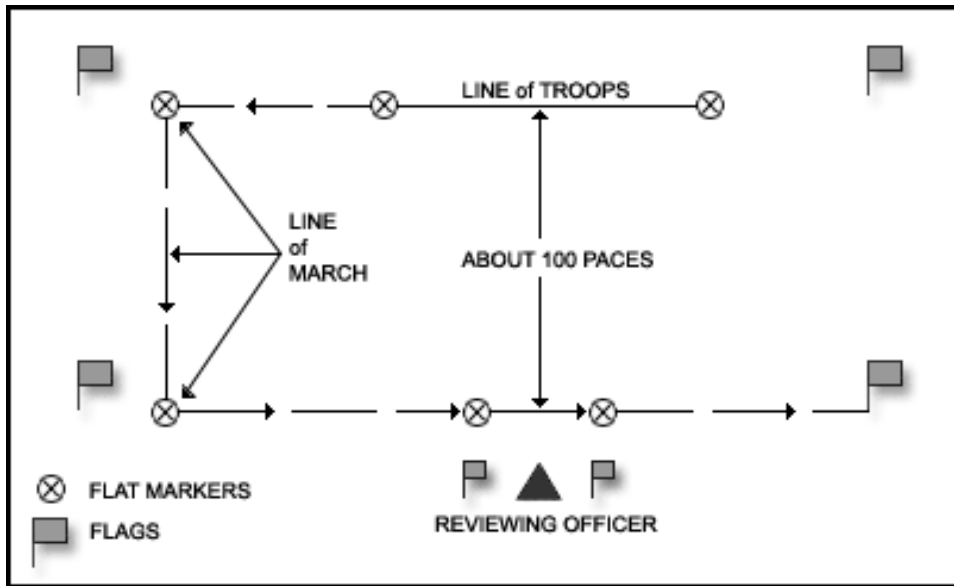
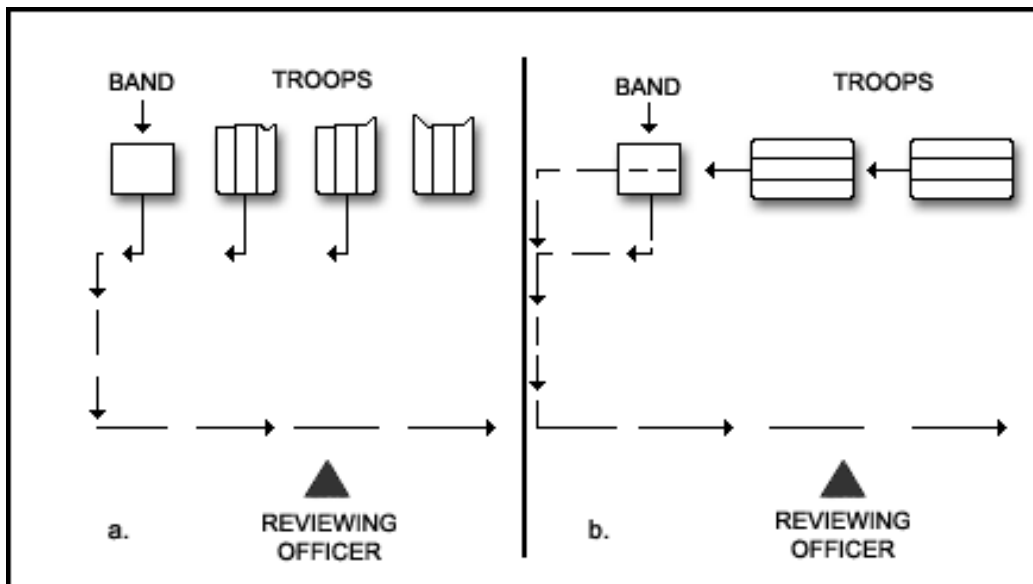


Figure 15. Field Marking in Preparation for a Review.

3. Cadet Formation

Cadets form in line for a review. Depending on the size and number of units involved in a ceremony and the conditions of the area of the review, the units of cadets can form either as a company in a column of platoons or with the company *en masse* (all platoons gathered together). The cadets may be armed with rifles or not as the commander of the unit directs.

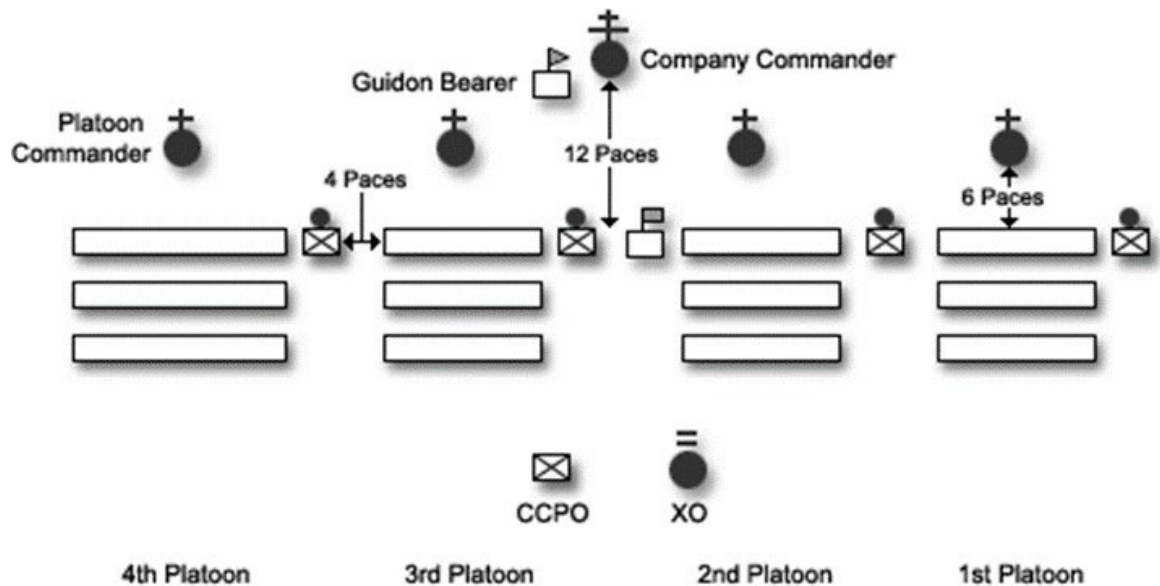


4. Troop Formations

- a. If other service units are participating jointly in an NJROTC unit's review, the order of march from the head of the column to the end is Army, Marine Corps, Navy, Air Force, Coast Guard. Further guidance can be determined by referring to SECNAVINST 5060.22.
- b. Cadets take their prescribed positions on the line of troops prior to the adjutant's (second in command) call for the review. Then, under the supervision of the adjutant, at the command Dress **RIGHT, DRESS**, the cadets are dressed to the right and the guides posted.
- c. After all the cadet units are dressed, the adjutant then presents the units to the commander of the troops. To present the cadets to the commander of the troops, the adjutant gives the command **PRESENT, ARMS**. When all the units are at present arms, the adjutant faces the commander of the troops and reports "**Sir, the parade is formed.**" The commander of the troops returns the salute and directs the adjutant to: **TAKE YOUR POST**. The adjutant then comes to carry sword, marches around the commander of the troops to his/her post in the staff, and halts. When the adjutant is in position, the commander of the troops then commands **ORDER, ARMS**.

5. Presentation and Honors

- a. As the reviewing officer approaches his/her post, the commander of the troops calls the cadet units to attention.
- b. When the reviewing officer is in position, the commander of the troops directs his/her command to present arms. When all units have presented arms, the commander of the troops faces the reviewing officer and salutes. The commander's staff salutes with him/her. Look at the illustration for the positions of the units and the spacing and positions of the officers.



6. Company In Line

- a. If the reviewing officer's rank entitles him/her honors, they are rendered to the reviewing officer by the band. When the honors are completed, the commander of the troops terminates his/her salute and brings the cadets to order arms.
- b. The reviewing officer, his/her staff, and all military spectators (in uniform and covered) salute at the first note of the music. They hold their salutes until the honors (music) are completed.

7. Inspection

- a. After the honors, the reviewing officer makes whatever general inspection of the units

he/she may desire. A detailed inspection is not generally a part of the ceremony or review. Should a detailed inspection be the case, it is conducted in the same manner as described in the Drill Manual.

- b. The band plays while the reviewing officer makes his/her inspection of the cadet units.
- c. After resuming his/her post after the inspection, the commander of the troops faces the units and orders the units to attention. After the units are at attention, presentations of decorations (which will be covered later) may be conducted, and the units are marched in review. If there is no presentation of decorations, the units march in review.

8. March in Review

- a. After the reviewing officer has taken his/her position in the reviewing area and the cadets are at attention, the commander of the troops commands **PASS IN REVIEW**. The commander and his/her staff proceed to the head of the column, and order the company along the route of the review.
- b. The commander of the troops and his/her staff salute and execute eyes right when six paces from the nearest member of the reviewing party. They hold their salutes and eyes position until six paces beyond the reviewing party.
- c. The platoon commanders of following companies (units) command **EYES, RIGHT** to their units in the same manner and place.
- d. After saluting the reviewing officer while marching in review, the commander of the troops and staff turn out of column and take a position on line with and to the right of the reviewing officer. The commander and staff return sword and render hand salutes as the national colors pass.
- e. When the last unit has passed in review, the commander of the troops faces the reviewing officer and renders a hand salute. When the salute is returned, he/she and the staff draw swords and follow the units off the parade grounds.

9. Presentation of Decorations

- a. Reviews for the purpose of the presentation of decorations are held, when practicable, when there are:
 - i. presentation of NJROTC awards and decorations
 - ii. decorations of organizational colors
- b. Formations and procedures for these reviews are the same as discussed previously until the reviewing officer completes his/her inspection. At this time, the following procedures are to be executed.

- c. Procedure for the positioning of persons to be decorated is as follows:
- i. After the reviewing officer has inspected the cadets and resumed his/her post, the commander of the troops, from his/her post, does an about face and commands **PERSONS TO BE DECORATED AND ALL COLORS, CENTER, MARCH**. On **MARCH**, persons to be decorated and all colors move by the most direct route to form single ranks in the center of the command, starting 15 paces in front of the line of company (unit) commanders. They form according to the rank of the decoration to be conferred, with the highest decoration on their right. Those to receive the same decorations take positions according to seniority within each group.
 - ii. Colors to be decorated form a single rank five paces in front of the center of the line of persons to be decorated. The color to receive the highest decoration is on the right.

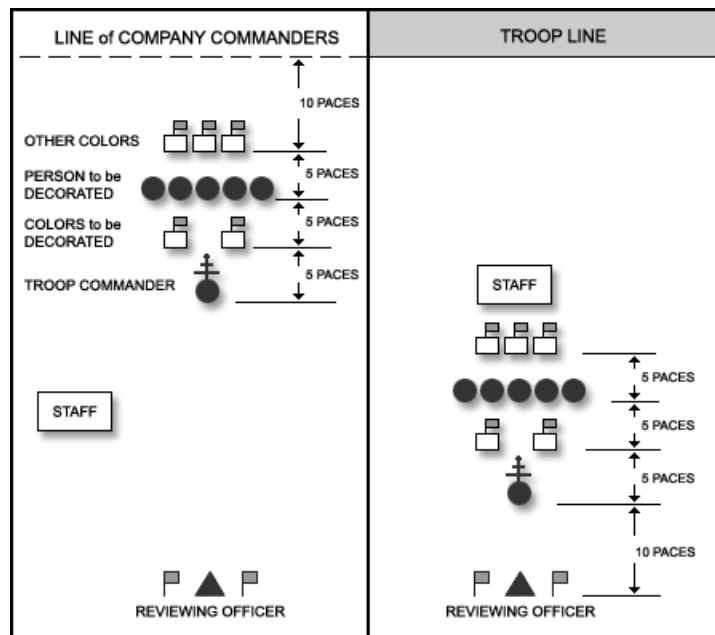


Figure 16. Presentation of Decorations.

- iii. All other colors with color guards form a single rank five paces behind the center of the line of persons to be decorated. Each color is in the same relative position as its parent unit within the formation for review. Note the illustration.
- iv. The presentation of the persons and/or colors to be decorated is made by the commander of the troops.
- v. The presentation of the awards/decorations commences with the reading of the orders and citations of the awards to be presented by a designated staff officer.

In ceremonies involving many awards that are the same, the commanding officer may direct that only one be read. For awards to individuals, the reviewing officer attaches the decoration on the uniform over the left breast pocket, presents the citation, and shakes the hand of each decorated person. Immediately after shaking hands, the person decorated salutes the reviewing officer. The salute is returned, and the reviewing officer proceeds to the next person being decorated. After shaking hands with the last person, the reviewing officer resumes his/her post.

- vi. At the command of the senior, the persons decorated/awarded form line at normal interval on the left of the local commander. The colors return to their posts by the most direct route. When the colors have taken their posts, the reviewing officer directs the commander of the troops to march the command in review.

G. STREET PARADES

1. **General.** In addition to the pass-in-review type events in which cadets will occasionally be involved, they will often be called upon to participate in street parades, etc. Street parades are considerably less formal with respect to the reports and procedures for conducting the parade than the military ceremonies, since most street parades are run by civilian organizations.
2. **Grand Marshal.** Street parades are organized and directed by a person designated as grand marshal. He appoints his aides and issues orders as to how the parade is to be conducted, where the individual units will form, and their positions in the line of march.
3. **Formations for Parades.** All participating units will form in the same manner as for a review. Normally, the units will form on side streets and march into position as directed by the grand marshal.
4. **Review of the Parade.** The grand marshal may lead the parade the entire distance or may review the parade from a location along the parade route.
5. **Importance of Participation.** Cadets should look upon participation in a parade, especially in the civilian community, as an important part of their training. Cadets should make every effort to prepare themselves and their uniforms in such a way as to bring credit on their school and unit. This is the opportunity to "strut your stuff" and make your parents and school proud of your efforts.

STUDY GUIDE QUESTIONS

CHAPTER 2: MILITARY CUSTOMS, COURTESIES, ETIQUETTE, AND CEREMONIES

1. What message does the U.S. flag give the American people and the world?
2. How does heraldry influence the way the American flag is placed and handled?
3. What procedure must be followed in raising and lowering the flag on a day when it is to be flown at half-staff?
4. What is meant by the following terms used in relation to the flag of the United States?
 - a. National flag
 - b. National ensign
 - c. Union Jack
5. What do personnel in uniform do during the pledge of allegiance and the national anthem?
6. What are the four types of ceremonies?
7. What is the composition of a review?
8. How is a street parade different from a military review?
9. Who organizes and directs street parades?
10. How does one properly retire the national flag when it is no longer suitable for display?
11. From memory, write the pledge of allegiance.
12. Describe the process for reviewing awards to individuals. Include actions

taken by both the presenter and the receiver.

13. Define the term "half-staff."

CRITICAL THINKING QUESTIONS

1. Do you recite the pledge of allegiance in your school? Do you feel you are forced to participate? How do you feel about saying it?
2. Do you think that most students think about what they are saying when they recite the pledge of allegiance? If not, do you think they would feel differently about it if they thought more about the meaning?
3. Customs, ceremonies, and traditions are important to the services, particularly to the Navy and Marine Corps. How would you define each, and how would you distinguish between them?

ACADEMIC CONTENT STANDARDS

Civics Standard 9 – Understands the importance of Americans sharing and supporting certain values, beliefs, and principles of American constitutional democracy. Benchmark: Understands how certain values are fundamental to public life.

Civics Standard 11 – Understands the role of diversity in American life and the importance of shared values, political beliefs, and civic beliefs in an increasingly diverse American society. Benchmarks: Knows a variety of forms of diversity in American society; knows major conflicts in American society that have arisen from diversity; knows ways in which conflicts about diversity can be resolved in a peaceful manner that respects individual rights and promotes the common good; knows why it is important to the individual and society that Americans understand and act on their shared political values and principles.

VOCABULARY WORDS

Badge

An emblem or other device displayed on a flag, generally on the fly.

Banner

A rectangular flag used by a king, prince, duke, or other noble. The coat of arms of the owner covers the banner's entire surface. The term is also loosely applied to a national flag (e.g., the "Star-Spangled Banner") and is today synonymous with flag.

Canton

The four corners of a flag are named cantons, especially the upper quarter of the hoist—that is, the upper left hand corner of the flag; the canton is sometimes also called the union.

Colors

The national and regimental or armorial flags carried by dismounted organizations (such as a color guard). Hence, the national color for Army and Marine Corps regiments is the U.S. flag. The term also applies to the national ensign flown aboard a naval vessel.

Ensign

A special flag based on a country's national flag and used exclusively on naval ships or merchant ships. The civil ensign is the merchant marine's flag. The U.S. flag serves as a national flag, naval ensign, and civil ensign. Great Britain, on the other hand, has a white ensign for naval ships, a red ensign for merchant ships, and a blue ensign for merchant ships commanded by an officer in the Naval Reserve.

Field

The ground of each division of a flag.

Fly

The half or edge of a flag farthest away from the staff or flagpole. This term also sometimes refers to the horizontal length of a flag.

Garrison Flag

A large U.S. flag flown at forts. During the War of 1812, garrison flags were 20 feet by 40 feet. The Star-Spangled Banner flown over Fort McHenry measured 30 feet by 42 feet.

Halyard

The rope by which a flag is raised on a flagpole.

Hoist

As an adjective: the half or edge of a flag nearest the staff or flagpole. This term also sometimes refers to the vertical width of a flag. As a verb: to raise a flag.

Hoist Rope

The rope on which a flag is flown on a flagpole.

Jack

A flag flown at the bow of warships when anchored. Great Britain's jack (the British Union Jack) combines the crosses of St. George, St. Andrew, and St. Patrick on a blue field. The U.S. Union Jack carries 50 white stars on a blue field (the canton of the naval ensign). According to U.S. Navy regulations, the U.S. Union Jack should be the same size as the canton of the naval ensign flown at the ship's stern.

Mullet

A five pointed star, representative of a knight's spur.

Staff

A small pole from which a flag is flown.

Standard

A flag which is colored according to the owner's livery and displays the owner's badge or badges instead of his arms. The term "national standard" is used to describe the national and regimental flags carried by mounted or motorized organizations.

Storm Flag

The U.S. flag flown at military installations during inclement weather. It is smaller than the U.S. flag usually flown at the installation.

Union

A flag or device of a flag symbolizing the union of countries or states. Also, the canton of (1) the U.S. flag, (2) British ensigns, and (3) British Commonwealth flags based on the British ensigns.

CHAPTER 3: PERSONNEL INSPECTION

OBJECTIVES

1. Describe the techniques for conducting a personnel inspection.
2. Explain the inspecting officer's duties when he/she inspects a platoon.
3. Explain the general inspection guidelines (items) that inspecting officers look for when inspecting a cadet in a platoon.

H. GENERAL

1. Personnel inspections often require a lot of preparation, and they reveal a lot of things about the individual cadets to the instructor and to school officials.
2. One of the positive things personnel inspections can promote as far as the individual cadets are concerned is that it gives hard-working cadets the opportunity to demonstrate the self-discipline, attention to detail, and pride they have in their unit and the things they have learned. The best part is that the naval science instructors get a chance to see what the cadets have learned.
3. The naval science instructors and school officials can learn the condition of many aspects of the training, morale, and leadership that exists in their unit by the appearance of the cadets. Parents can also see the value of the NJROTC program and take great pride in their sons and daughters for all their efforts.

I. FORMING FOR INSPECTION

1. The company/platoon is the basic unit for inspection. The company falls in for inspection by platoons. A unit composed of a battalion may be inspected *en masse* for special occasions. Before the inspection, the cadets will have been informed of the time to fall in and will be in ranks and mustered by that time. Inspections normally occur as follows:
 - i. **PREPARE FOR INSPECTION**. This is the command given by the company commander at the appointed time for the inspection. At this time, the following actions take place.

- (a) The platoon commander of the first (base) platoon faces his platoon and gives the command **OPEN RANKS, MARCH**. The cadets in the first rank take two steps forward, the second rank takes one step forward, and the third rank remains stationary. The cadets automatically come to dress right, while at the same time raising their left arm to get the proper interval.
- (b) The first platoon commander aligns each rank by sighting down the rank and directing individuals to move if not in line. After verifying the alignment, the platoon commander marches to a position three paces beyond the front rank, faces left, and commands **READY, FRONT; COVER**. The platoon leader then takes one pace forward and faces front. It is in this position that the platoon commander receives the inspecting officer.
- (c) Each of the other platoon commanders aligns his platoon in sequence on the first platoon. When all platoon commanders have taken their posts, the company commander reports the company ready for inspection. When acknowledged, he gives the command **AT EASE** or other command ordered.

J. INSPECTING OFFICER'S TOUR

1. The inspecting officer proceeds to the first platoon and takes a position one pace in front of and facing the platoon and the platoon commander.
 - i. As the inspecting officer approaches the platoon, the platoon commander turns his head and gives the command **ATTENTION**.
 - ii. Upon the arrival of the inspecting officer, the platoon commander salutes and reports "First platoon (Drill Team, etc.) is standing by for your inspection, Sir." If the platoon commander is armed, he will go to return sword after saluting and being inspected.
 - iii. The inspecting officer then proceeds to the first person in the first rank (the guide). The inspecting officer, at his discretion, may direct the platoon commander to put the ranks not being inspected at ease. If this is the case, the platoon commander will bring those ranks to attention when it is their turn to be inspected.

- iv. The platoon commander will move to a position ahead of the inspecting officer as he inspects. If armed with a sword, the platoon commander will execute **RETURN SWORD** prior to joining the inspecting officer. The inspecting officer proceeds from cadet to cadet by stepping off to the right as in marching, halting, and executing a left face. (The platoon commander must follow this same procedure in order not to be in the way of the inspecting officer).
- v. After inspecting the front of the first rank, the inspecting officer inspects the rear of that rank and so forth for each rank.
- vi. At the conclusion of the inspection, the platoon commander proceeds to a position three paces in front of and one pace to the side of the first rank, faces left (draws sword if so armed), commands **ATTENTION**, takes one step forward, then faces right.
- vii. The inspecting officer proceeds to a position one pace in front of the platoon commander and makes any remarks he deems necessary. The inspecting officer and the platoon commander exchange salutes, and the inspecting officer proceeds to the next platoon.
- viii. Upon completion of the inspection of each platoon, its commander faces left and orders **CLOSE RANKS, MARCH**. At the command **MARCH**, the platoon commander moves by the most direct route and takes his post six paces in front of the center of his platoon. The command **AT EASE** or **PARADE REST** will be given from this position.

K. INSPECTION GUIDELINES

1. No two inspecting officers inspect in the same way. Some look at the overall appearance of the individuals, while others may act as though they want to see their face in the reflection from your "spit shined" shoes.
2. An important aspect that an inspecting officer must try to keep in mind is not only what **looks** good but also what is **correct** according to the uniform regulations.

3. In general, the inspecting officer should start with the overall look of the cadets and then check specific items. The first impression is very important.
 - i. Does everything look like it is in the right place and worn correctly?
 - ii. Does the cadet display good posture?
 - iii. Is the cap clean, neat, positioned correctly, and in good repair?
 - iv. Are all insignia and devices positioned correctly?
 - v. Is the cadet's face and hair clean and groomed properly?
 - vi. Are the trousers/skirts, shirts, etc., clean, pressed, properly fitted, and in good repair?
 - vii. Are the shoes shined and in good repair?
 - viii. Are the ribbons and/or awards correct (having been earned), worn in the proper order of precedence and properly positioned on the uniform?
 - ix. Are the service designations (stars) positioned properly?
 - x. Is the aiguillette worn on the correct shoulder?
 - xi. Is the cadet wearing unauthorized jewelry?
 - xii. Has the cadet tied the necktie correctly?

4. The Sample Inspection Score Sheet that follows is typical of inspection score sheets in use throughout the program. However, regardless of the score sheet being used, the inspector is cautioned to look first at the cadet being inspected, reviewing what is correct/incorrect with the cadet, and then use the score sheet to record the results. Inspectors should not use the sheet as a checklist.

L. SAMPLE INSPECTION SCORE SHEET

Cadet's Name:	
Score:	
Item	Points Deducted
Cap: (Cleanliness/neatness/brim/chinstrap/buttons/cover/insignia)	
Hair: (Length/neatness/taper/cleanliness/style)	
Shave: (neck/face/mustache)	
Jewelry: (amount/type/appropriateness)	
Shirt/Jacket: (fitness/cleanliness/press)	
NJROTC Patch: (position/condition/sewing)	
Collar Devices: (position/condition)	
Tie: (position/condition)	
Name Tag (position/condition)	
Ribbons: (order/position/condition)	
Fingernails: (cleanliness/trim/color)	
Gig line: (Trousers in line/belt buckle/shirt in line)	
Belt/Buckle: (fit/condition)	
Trousers/Skirt/Slacks: (length/cleanliness/fit/press)	
Shoes: (condition/shine/heels/welts)	
Socks/Hosiery (color/condition)	
Posture Bearing:	
Other Deductions:	
Total Points Deducted from 100 Possible Points	
Note: Although the score sheet can be used for all cadets, some units may prefer to make separate male and female score sheets with additional items of inspection. Likewise, many units have	

their own rules for grading personnel inspections.

STUDY GUIDE QUESTIONS
CHAPTER 3: PERSONNEL INSPECTION

1. What is one of the positive results personnel inspections can promote?
2. What can the naval science instructors and school officials learn from inspecting a unit?
3. What is considered the basic unit for inspection?
4. What is the command given by the company commander to the platoon commanders at the appointed time for inspection?
5. What does the first squad do when the platoon commander of a three-squad platoon gives the command "Open Ranks, MARCH"?
6. What does the third squad do when the platoon commander of a three-squad platoon gives the command "Open Ranks, MARCH"?
7. After verifying alignment, the platoon commander marches to a position _____ pace(s) beyond the front rank, faces left, and commands "Ready, FRONT, COVER."
8. The inspecting officer proceeds to the first platoon and takes a position _____ pace(s) in front of and facing the platoon and the platoon commander.
9. Upon arrival of the inspecting officer, the platoon commander salutes and reports _____.
10. While the inspecting officer inspects each squad, the platoon commander will move to a position _____ of the inspecting officer as he inspects.
11. At the conclusion of the inspection, the platoon commander proceeds to a position _____ pace(s) in front of and _____ pace(s) to the side of the first rank.
.
12. Upon completion of the inspection of each platoon by the inspecting officer, its platoon commander faces left and orders _____.

13. What can the platoon commander order the platoon to do after it has closed ranks?

14. What position does the platoon commander take after the inspecting officer departs the platoon and the platoon has closed its ranks?

15. The inspecting officer should start the inspection of each cadet with an overall look and then check specific items. What are the most correct items to be inspected by the inspecting officer?

16. What general items should inspecting officer inspect during inspection?

17. When inspecting a cap, what items are normally checked by the inspecting officer?

18. When inspecting cadet hair, what items are normally checked by the inspecting officer?

CRITICAL THINKING QUESTIONS

Why are ceremonies, customs, and courtesies important to military organizations?

How did the tradition of personnel inspections start?

EXTENSION ACTIVITY

Research various military JROTC organizations regarding personnel inspection, honors, and ceremonies and how those organizations personnel inspections differ from the NJROTC personnel inspection requirements.

INTERDISCIPLINARY CONNECTION

Research the origins of the British Royal Navy's military personnel inspections and the historical background that formed the basis for the United States Navy's personnel inspections and traditions.

ACADEMIC CONTENT STANDARDS

Language Arts Standard 7: Demonstrates competence in the general skills and strategies for reading a variety of informational texts. Benchmarks: Applies reading skills and strategies to a variety of informational texts; knows the defining characteristics of a variety of informational texts; determines the effectiveness of techniques used to convey viewpoint; uses discussions with peers as a way of understanding information.

Historical Understanding Standard 2: Understands the historical perspective. Benchmarks: Understands that specific individuals and the values those individuals held had an impact on history; analyzes the influence specific ideas and beliefs had on a period of history; analyzes the effects that specific "chance events" had on history; analyzes the effects specific decisions had on history.

VOCABULARY WORDS

Inspection

A checking or testing of an individual against established standards.

Self-discipline

Correction or regulation of oneself for the sake of improvement.

En masse

As a whole.

Gig line

Refers to the alignment of the shirt button placket, the belt buckle, and the trouser fly. When properly aligned, all three form one continuous line.

Smile

The separation between the black band surrounding the bottom of the combination cover and the seam of the white or khaki cover. There should be no smile showing in the cover.

(THIS PAGE INTENTIONALLY LEFT BLANK)